



VOLUME 10.

BUILDING AMERICA BEST PRACTICES SERIES



Retrofit Techniques & Technologies:

Air Sealing

A Guide for Contractors
to Share with Homeowners

PREPARED BY

Pacific Northwest National Laboratory
& Oak Ridge National Laboratory

April 12, 2010

BUILDING AMERICA BEST PRACTICES SERIES

Retrofit Techniques and Technologies:

Air Sealing

A Guide for Contractors to Share with Homeowners

PREPARED BY

Pacific Northwest National Laboratory

Michael C. Baechler

Theresa Gilbride, Marye Hefty, Pam Cole, and Jennifer Williamson

and

Oak Ridge National Laboratory

Pat M. Love

April 12, 2010

Prepared for the U.S. Department of Energy
under Contract DE-AC05-76RLO 1830

PNNL-19284

This report was prepared as an account of work sponsored by an agency of the United States Government. Neither the United States Government nor any agency thereof, nor Battelle Memorial Institute, nor any of their employees, makes any warranty, express or implied, or assumes any legal liability or responsibility for the accuracy, completeness, or usefulness of any information, apparatus, product, or process disclosed, or represents that its use would not infringe privately owned rights. Reference herein to any specific commercial product, process, or service by trade name, trademark, manufacturer, or otherwise does not necessarily constitute or imply its endorsement, recommendation, or favoring by the United States Government or any agency thereof, or Battelle Memorial Institute. The views and opinions of authors expressed herein do not necessarily state or reflect those of the United States Government or any agency thereof.



You can learn more about Building America and download additional copies of this document, other best practices, research reports, and case studies at

www.buildingamerica.gov

Preface

The U.S. Department of Energy recognizes the enormous potential that exists for improving the energy efficiency, safety, and comfort of existing American homes. This series of Retrofit Techniques and Technologies describes approaches for homeowners and builders working on existing homes. This guide will help homeowners identify ways to make their homes more comfortable, more energy efficient, and healthier to live in. It also identifies the steps to take, with the help of a qualified home performance contractor, to seal unwanted air leaks while ensuring healthy levels of ventilation and avoiding sources of indoor air pollution. Contractors can use this document to explain the value of these air sealing measures to their customers. The references in this document provide further explanation of air sealing techniques and technologies.

Studies show that the measures described in this guide can typically achieve whole-house energy savings of 10% to 20% over pre-retrofit energy usage. In older homes or homes with greater levels of air leaks, savings may be much higher.

These practices are based on the results of research and demonstration projects conducted by the U.S. Department of Energy's Building America and Home Performance with ENERGY STAR sponsored by the U.S. Environmental Protection Agency and DOE. Home Performance with ENERGY STAR offers a comprehensive, whole-house approach to improving the energy efficiency and comfort of existing homes and requires a test-in/test-out to test combustion products (www.energystar.gov/homeperformance).

DOE's Building America has worked with some of the nation's leading building scientists and more than 300 production builders on over 41,000 new homes. Building America's research applies building science to the goal of achieving efficient, comfortable, healthy, and durable homes.

Please submit your comments via e-mail to:
George James (George.James@ee.doe.gov)

Contents

Preface	i
Introduction.....	1
Finding a Contractor	3
Test In/Test Out.....	4
Step 1. The Audit	4
Step 2. Installing Air Sealing Measures	5
Step 3. Testing Out.....	5
Diagnostic Tools Used During Test-In Test-Out	6
Safety and Health Issues	7
Ventilate it Right.....	8
New Code Air Sealing Requirements	9
An Air Sealing Checklist.....	10
1. Air Barrier and Thermal Barrier Alignment	12
2. Attic Air Sealing.....	13
3. Attic Kneewalls.....	14
4. Duct Shaft/Piping Shaft and Penetrations.....	15
5. Dropped Ceiling/Soffit	16
6. Staircase Framing at Exterior Wall/Attic.....	17
7. Porch Roof	18
8. Flue or Chimney Shaft.....	19
9. Attic Access/Pull-Down Stair.....	20
10. Recessed Lighting	21
11. Ducts	22
12. Whole-House Fan Penetration at Attic.....	24
13. Exterior Walls	25
14. Fireplace Wall	26
15. Garage/Living Space Walls	27
16. Cantilevered Floor	29
17. Rim Joists, Sill Plate, Foundation, and Floor	30
18. Windows and Doors	32
19. Common Walls Between Attached Dwelling Units.....	33

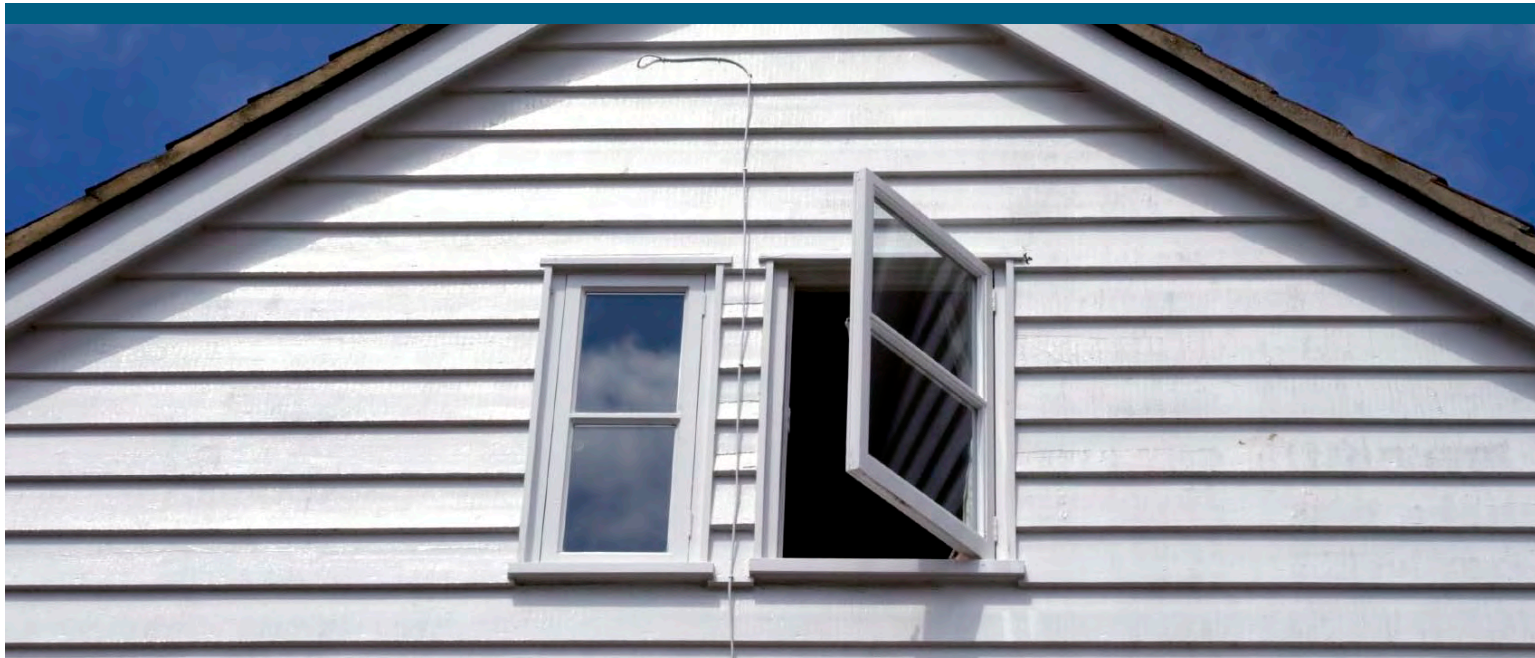

Introduction



Imagine opening a window in your house and leaving it that way 24 hours a day, all year long. On balmy spring days, the breeze wouldn't be so bad. But, in the freezing cold of winter and the sticky heat of summer, with the furnace or air conditioner on, smart homeowners would recognize they might as well be throwing buckets of quarters out the window to pay for the escaping heated or cooled air.

Air leaks in most existing homes add up to an open window in your home. Air sealing is one of the least expensive and most cost-effective measures you can take to improve your home's comfort and energy efficiency. By sealing uncontrolled air leaks, you can expect to see savings of 10% to 20% on your heating and cooling bills, and even more if you have an older or especially leaky house. But, before you grab your caulk gun, there are some things you should consider.

Many older homes lack proper ventilation, so they depend on those cracks and leaks to let in air, especially when fuel-burning appliances are operating inside the home. Without ventilation, carbon monoxide and air pollutants from cleaning chemicals, combustion appliances, and off-gassing household products can build up, creating an unhealthy and even dangerous environment in the home. Opening windows is one way to ventilate, but there are times when opening the windows is not practical (e.g., it is too cold or too hot outside). Fortunately there are other options for bringing fresh air into your home. A *certified* contractor can help you get all the energy savings and comfort possible from a well sealed home, along with the safety of proper ventilation.





Your house is a system and every component in it works together. Adding insulation and sealing air leaks can improve the energy efficiency of your home and improve your home's comfort and durability. However, every change you make to the building's envelope (walls, floors, and ceiling) and components will affect how the home works to keep out the elements and keep your family safe and comfortable. Tightening the building envelope without providing appropriate ventilation can cause pressure imbalances or negative pressure in the house. This negative pressure can set up the conditions for backdrafting of fireplaces or fuel-burning (combustion) appliances and may draw pollutants into the home. A trained contractor understands how systems work together to keep your house operating as it should.

This guide gives homeowners tips on where to find a good contractor, how to get your home tested for airtightness, where the biggest air leaks usually are and how to fix them, what the potential health and durability concerns are, and how your contractor can handle these concerns—in short, what you need to know to proceed with confidence to a more comfortable, energy-efficient, and healthy home for your family.

If you are a contractor, share this guide with your customers so that they can understand the process you will follow to make their home more comfortable, durable, and energy efficient. See the references in this guide for detailed explanations of air sealing techniques.

Air Sealing versus Insulation:

Why do I need to air seal?
I thought all I needed to do was add more insulation.

Insulation is like a fuzzy wool sweater on a winter day. It will certainly keep you warm if the air is calm. But, if the wind picks up, you are going to need a windbreaker to keep the breeze from carrying away the heat. Air sealing is like adding the windbreaker. It keeps the conditioned air where it belongs.

Keys to indoor air quality:

- Remove pollutant sources, if possible.
- Avoid combustion (fuel-burning) appliances that do not directly vent to the outdoors.
- Never use non-vented combustion (e.g., kerosene) heaters inside the house.
- Fix water leaks and moisture management problems.
- Test for radon and carbon monoxide levels.
- Provide adequate ventilation.



Certified contractors are trained in building science principles to know the safest and most effective ways to improve your home's energy efficiency.



Finding a Contractor

There are two nationally recognized energy certifications for home energy auditors and contractors: the Building Performance Institute (BPI) Building Analyst certification and the Residential Energy Services Network (RESNET) HERS Rater certification. Historically, BPI certification has focused on understanding the building science of retrofitting *existing* homes and RESNET has focused on building science in *new* home construction.

BPI is a nonprofit organization that accredits auditors, contractors, and other building professionals. Auditors or building analysts specialize in evaluating building systems and potential energy savings in homes. The certified BPI Building Analyst energy auditor has passed both written and field exams, and must recertify every three years. Contractors learn about building systems and are trained to install energy-efficiency measures. For more information see www.BPI.org

A certified RESNET energy auditor is called a HERS Rater. HERS (the Home Energy Rating System) provides a miles-per-gallon type rating for expected energy consumption in homes based on computer models. Each home receives a score that can be compared with other new or existing homes—the lower the score, the more efficient the home. More information about HERS can be found at www.natresnet.org.

An easy way to find a certified contractor is through a national or regional retrofit program. One such program is Home Performance with ENERGY STAR, a national program from the U.S. Environmental Protection Agency and the U.S. Department of Energy that promotes a comprehensive, whole-house approach to energy-efficiency improvements. To find a Home Performance with ENERGY STAR contractor for your area, go to www.energystar.gov and click on the link for Home Performance with ENERGY STAR. Next, click on the “locations” link for certified contractors in your state. For cities and states without Home Performance with ENERGY STAR contractors, you can find lists of contractors in your area who understand the building science whole-house approach through the BPI and RESNET websites: www.bpi.org or www.natresnet.org

Many local, state, and federal entities offer grants and tax credits for energy-efficient home improvements. Check with your local utility or city, or check the DOE-sponsored Database of State Incentives for Renewables and Efficiency (DSIRE) at www.dsireusa.org. This site is frequently updated and is a wealth of information, organized by state, on state, local, utility, and federal incentives, tax credits, and policies that promote renewable energy and energy efficiency.

Test-In/Test-Out

If you are participating in a home performance or weatherization program, one of the first steps may be an energy audit. Depending on the program, this audit may be conducted by an independent auditor or by a weatherization contractor. Details will vary by location and program, but here is what you can typically expect.

Step 1 - The Audit

First, the contractor or auditor should inspect, evaluate, and analyze your home. This step is commonly called an audit, but that term has been around for a long time and can mean many things. Perhaps the most important part of the audit is the conversation between the occupants and the auditor. Be prepared to talk about comfort issues and energy bills.

Here is what your audit should include:

- **SIZING THINGS UP** - The auditor may measure your house and identify square footage, window area, door area, and the condition of insulation, mechanical equipment, and air leaks.
- **TESTING IN** - The auditor will use diagnostic equipment to measure how your house performs in ways that cannot be seen by eyes alone. These tests may include a blower door test, duct pressurization testing, infrared cameras and smoke sticks, combustion safety testing, and carbon monoxide sampling. A heating and cooling contractor may evaluate your furnace and air conditioning system supply and return air balance. More information on these tests is included in the next section.
- **COST-BENEFIT ANALYSIS AND ESTIMATES** - The auditor will estimate the costs of installing the measures and use a computer program to estimate the expected energy savings. The cost of the measures divided by the annual savings will tell you the “simple pay back” or how many years the measures will take to pay for themselves. Often investments in energy efficiency provide a better return than stocks, bonds, or savings accounts, while improving comfort.
- **GETTING THE GREEN LIGHT** - Expert visual inspections and tests can identify safety and operational problems that may require attention before any other work on the house proceeds. Combustion safety issues must be addressed before air sealing begins. Auditors should also point out any obvious sources of indoor air pollution. Dry rot and moisture problems must be repaired.



Your contractor may test duct leakage as part of the home's energy audit.

Test-In/Test-Out Steps

- 1 Audit
- 2 Installing Air Sealing Measures
- 3 Testing Out

Do not proceed with retrofit work if

- **The house has active knob and tube wiring** - Rewire the house first.
- **The house has vermiculite insulation** - Vermiculite insulation may contain asbestos. Contact your state department of health.
- **Bathroom fans are vented into the attic** - Vent fans to outside.
- **The house has a leaking roof** - Repair the roof leak before air sealing and insulating. (Lstiburek 2010)



(left) Auditors will check for dry rot and moisture problems as well as air leakage.



(middle) Your contractor will visually inspect the home and test for safety concerns before air sealing begins.



(right) Once safety and health issues have been addressed, your contractor will proceed with air sealing measures.

Step 2. Installing Air Sealing Measures

Within a week or so, your home performance contractor should analyze the test results and provide you with a detailed proposal including a prioritized list of energy-efficiency measures, packaged options, and cost estimates. Critical safety or health issues should be dealt with before work proceeds on the agreed-upon energy-efficiency improvements. Your contractor understands state and local building codes and will work with code officials when necessary to ensure that the improvements meet building code requirements. Your contractor may bring in specialized subcontractors if needed.

Step 3. Testing Out

Testing out means repeating some of the tests used at the beginning of the audit process now that the installation is complete. Final testing verifies that renovations have improved the home's performance and that safety standards have been met. Some contractors offer a guaranteed level of energy savings on their retrofit projects. Homeowners receive a report summarizing the improvements completed, test results, and estimated energy savings. In addition to testing out, in Home Performance with ENERGY STAR, at least 1 in 20 homes is spot-checked by independent third-party building professionals to ensure program compliance.

Form 3600
Site Registration—Universal
Home Energy Savings

Energy Trust of Oregon, Inc.

To be completed by Participant for all sites that have not had a Home Energy Review

Conservation Services Group (CSG) is a Program Management Contractor for Energy Trust of Oregon, Inc.

The Home Energy Savings program must receive applications within 90 days from the date of installation. Funds for incentives are limited and available on a first come, first served basis. Details of this program, including benefits, are subject to change without prior notice.

Participant Information

Participant Name: _____ Date: _____

Site Address: _____ City: _____ State: _____ Zip: _____

Email: _____ Daytime Telephone: _____ Home Telephone: _____

Participant Type: Homeowner Property Owner or Manager Occupancy Owner Tenant

Electric Utility Information

Pacific Power Account Number Portland General Electric (PGE) Account Number

Other Electric Utility (specify): _____

Gas Utility Information

NW Natural Cascade Natural Gas

Site Information

Year Built: 1973 Square Feet: 2912 Number of Levels: 3

Age of Heating System: 2006

Heating Fuel: Electric Gas Propane Other (specify): _____

Central Forced Air System: Yes No Cooling: Central A/C Room A/C Heat Pump None

Age of Water Heater: 2004

Water Heater Fuel: Electric Gas Propane Other (specify): _____

Water Heater Capacity: 50 gallons Tankless

Form 3600 v3 09/08 Rev. 08/08

Home Energy Savings • Conservation Services Group (CSG)
P.O. Box 847 • Portland, Oregon 97208-0847
503.221.1822 • Fax 503.221.0752
www.energytrust.org

Auditors use forms like this one from Energy Trust of Oregon for test-in and test-out.

Diagnostic Tools for Test-In and Test-Out

A trained contractor may run these and other diagnostic tests on your home as part of the test-in and test-out process.

Combustion Safety

High-efficiency combustion appliances are usually sealed combustion, meaning that they draw in oxygen from outside the home through a dedicated vent and send exhaust fumes outside through a separate, dedicated vent pipe. These exhaust flues are sealed to prevent backdrafting, where exhaust fumes come back down the flue into the living space.

Older and less efficient combustion appliances are sometimes atmospheric vented, meaning they draw combustion air from the room in which they are located, often through an opening at the base of the exhaust pipe. Auditors or contractors will check combustion appliances such as stoves, furnaces, water heaters, and fireplaces for carbon monoxide levels, backdrafting, and other safety hazards, such as gas leaks and cracked heat exchangers. If problems are identified, no air sealing occurs until the problem is fixed. These may be serious safety problems; in rare instances, occupants may need to leave the house until problems are repaired.

Blower Door

A blower door uses a calibrated fan to measure how much air a home leaks. The blower door mounts into an exterior door frame. The fan pulls air out of the house, lowering the air pressure inside. Outside air then flows into the house through all unsealed cracks and openings. The amount of fan pressure required by the fan to maintain the test pressure tells the auditor how much leakage the house has. Some contractors will seal simple air leaks as they are identified while the blower door is operating.

Infrared Camera

An infrared camera produces images called thermographs that show variations in temperature not visible to the human eye. Infrared cameras can be used during blower door tests to capture images of temperature differences that can indicate air leakage or other conditions such as gaps in insulation and overheating circuits.

Duct Blaster

Leaky ducts in attics or crawlspaces can account for 20% or more of a home's heating and cooling energy losses. A Duct Blaster (duct pressurization test) uses a calibrated fan to test the air leakage rate in air ducts. Another approach uses a blower door and a shallow pan (a pressure pan) to cover each register and grill to measure and prioritize duct leaks.



(top) Your contractor can use a blower door to measure overall house air leakage.

(bottom) The infrared cameras can show air leaks not visible to the naked eye.

If initial testing or inspections identify any health or safety problems, no air sealing occurs until the problem is fixed.



(top) Studies show homes and garages may contain over 150 household products that may be harmful to humans.

(bottom) Lack of ventilation, poor moisture management, installation issues, and pressure imbalances combine leading to mold problems inside walls.

Be Safe:

All combustion appliances should be tested for backdrafting. Replace natural draft combustion appliances with sealed combustion, induced draft, or power-vented appliances, if possible. Homes with combustion appliances should have carbon monoxide detectors that meet UL 2034.

Safety and Health Issues

Inspection and testing can identify health and safety issues that should be fixed before any air sealing or other efficiency improvements are made. Taking care of these issues is important to your family's health, and these issues should be fixed before doing any home improvements. If the problems are severe, fix them before returning home. Here are some problems to watch for.

- **BACKDRAFTING** – Air pressure imbalances between the outside and inside or between rooms of the house can cause fireplaces, furnaces, and other appliances that burn fuel (such as wood and natural gas) to pull exhaust gases back into the house instead of letting them vent up the flue. This situation is known as backdrafting. Carbon monoxide (CO), a toxic gas without odor and color, can backdraft into homes causing illness and death.
- **ROLL-OUT** – Combustion appliances may have a pilot light flame. Backdrafting, air pressure imbalances, and mechanical problems can cause the pilot to blow out, or worse, the flame can “roll out” of the appliance, causing a house fire.
- **MOISTURE PROBLEMS** – If the home is not properly ventilated, water vapor from showering, cooking, breathing, and burning fuels can concentrate in the home increasing humidity levels. This can lead to mold and mildew, dust mites, wood rot, material damage, and subsequent health and structural problems.
- **AIR POLLUTANTS** – Many homes contain hazardous substances (such as cigarette smoke, volatile organic compounds and other offgases from carpets, paints, finishes, and home electronics; cleaning chemicals; and pesticides) as well as allergens (such as pet dander and dust mites). It is important to avoid or exhaust pollutants at their source. Also, air pressure imbalances between the outside and inside of the house can draw in pollutants from outside. These can include solvents and car exhausts from attached garages or radon emanating from the soil.
- **RADON** – Radon is a naturally occurring radioactive gas. Radon gas is colorless, odorless, and tasteless and cannot be detected by human senses. In some geographic areas with high concentrations of radon in the soil, it can accumulate in the home and may adversely affect human health.

Ventilate it Right

Studies show the average American spends up to 90% of their time indoors. About 23 million people including 6.8 million children in the United States now suffer from asthma. Some see a correlation and point to indoor air pollutants—chemicals, gases, mold, dust, etc.—as a culprit. To provide fresh air in your older home, your contractor may recommend adding mechanical ventilation.

An old adage for building scientists is “build tight, ventilate right.” When air leaks in the home are sealed up, mechanical ventilation may need to be added.

There are several options for mechanical ventilation systems. Spot ventilation, using exhaust-only fans in the kitchen and bathroom, removes water vapor and pollutants from specific locations in the home, but does not distribute fresh air. Balanced ventilation systems, like air-to-air exchangers, heat-recovery ventilators, and energy-recovery ventilators, both supply and exhaust air. Your contractor can help you determine which one is most appropriate for your specific climate, house design, and budget.

Pros and Cons of Various Mechanical Ventilation Systems

Ventilation Type	Pros	Cons
Exhaust Only (air is exhausted from the house with a fan)	<ul style="list-style-type: none"> • Easy to install • Simple method for spot ventilation • Inexpensive 	<ul style="list-style-type: none"> • Negative pressure may cause backdrafting • Makeup air is from random sources • Removes heated or cooled air
Supply Only (air is supplied into the house with a fan)	<ul style="list-style-type: none"> • Does not interfere with combustion appliances • Positive pressures inhibit pollutants from entering • Delivers to important locations 	<ul style="list-style-type: none"> • Does not remove indoor air pollutants at their source • Brings in hot or cold air or moisture from outside • Air circulation can feel drafty • Furnace fan runs more often unless fan has an ECM (variable-speed motor)
Balanced Air Exchange System (heat and energy recovery ventilators)	<ul style="list-style-type: none"> • No combustion impact • No induced infiltration/exfiltration • Can be regulated to optimize performance • Provides equal supply and exhaust air • Recovers up to 80% of the energy in air exchanged 	<ul style="list-style-type: none"> • More complicated design considerations • Over ventilation unless the building is tight • Cost

Heat and Energy Recovery Ventilation Systems

Heat-recovery ventilators (HRVs) and energy-recovery (or enthalpy-recovery) ventilators (ERVs) both provide a controlled way of ventilating a home while minimizing energy loss by using conditioned exhaust air to warm or cool fresh incoming air. There are some small wall- or window-mounted models, but the majority are central, whole-house ventilation systems that share the furnace duct system or have their own duct system.

The main difference between an HRV and an ERV is the way the heat exchanger works. With an ERV, the heat exchanger transfers water vapor along with heat energy, while an HRV only transfers heat. The ERV helps keep indoor humidity more constant. However, in very humid conditions, the ERV should be turned off when the air conditioner is not running. Air-to-air heat exchangers or heat recovery ventilators (HRV’s) are recommended for cold climates and dry climates. Energy recovery ventilators (ERV’s) are recommended for humid climates.

Most energy recovery ventilation systems can recover about 70%–80% of the energy in the exiting air. They are most cost effective in climates with extreme winters or summers, and where fuel costs are high. Energy recovery ventilation systems operated in cold climates must have devices to help prevent freezing and frost formation.

Ventilation – too little, too much, just right

Too little ventilation can lead to indoor air quality problems, too much can waste energy and cause comfort issues. Your contractor will use ASHRAE Standard 62.2 and other industry guidelines to determine how much passive and mechanical ventilation is right for your home.



The holes in the sill plate were properly air sealed during construction of this house.

New Code Air Sealing Requirements

The 2009 International Energy Conservation Code (IECC) and the 2009 International Residential Code (IRC) have several new mandatory requirements for air sealing in new construction and additions. These codes apply to new construction where adopted by local jurisdictions. In general, these requirements do not apply to retrofit projects unless the project adds living space to the building or changes the building's energy load. The existing, unaltered portions of the structure are not required to comply with all of the requirements of the 2009 IECC or IRC. However, Building America recommends implementing these requirements in existing portions of your home wherever they are applicable and your budget allows or health and safety concerns make them necessary.

The requirements regarding new buildings can be summarized in this section excerpted from IECC, Chapter 4, Section 402.4, Air Leakage (mandatory) (quoted verbatim). Builders can see IECC 2009, Chapter 4 "Residential," and IRC 2009, Chapter 11 "Energy Efficiency," for more details:

"The building thermal envelope shall be durably sealed to limit infiltration. The sealing methods between dissimilar materials shall allow for differential expansion and contraction. The following shall be caulked, gasketed, weather stripped or otherwise sealed with an air barrier material, suitable film, or solid material:

1. all joints, seams and penetrations,
2. site-built windows, doors, and skylights,
3. openings between window and door assemblies and their respective jambs and framing,
4. utility penetrations,
5. dropped ceilings or chases adjacent to the thermal envelope,
6. knee walls,
7. walls and ceilings separating a garage from conditioned spaces,
8. behind tubs and showers on exterior walls,
9. common walls between dwelling units,
10. attic access openings,
11. rim joists junction,
12. other sources of infiltration."

An Air Sealing Checklist

This section provides descriptions of the areas of the home most likely to have air leakage, when to address those problems, durability and health concerns related to the problems, and references for more information. Additional information on how to identify and fix these problems and other building science information can be found in the Building America Best Practices guides produced by DOE and available for free download at www.buildingamerica.gov. Work with your contractor to determine which of these measures are most needed and most cost-effective.

Common air sealing trouble spots are shown on the graphic below and listed on the following page. Each of these trouble spots is described further in the pages that follow.

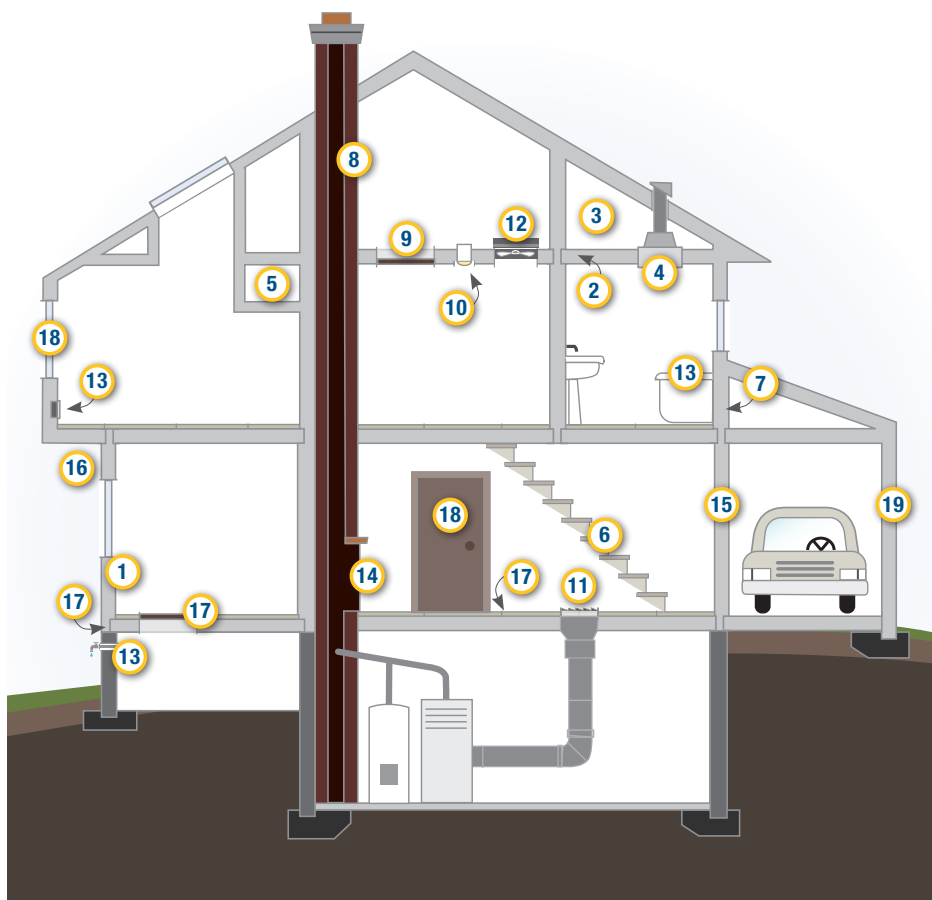

Building America research identifies 19 key areas where air sealing can improve a home's energy efficiency, comfort, and building durability. The information in this guide can help you find a certified home performance contractor and work with your contractor to identify problem areas, prioritize projects with safety in mind, and start sealing the air leaks in your home for cost-effective energy savings.

Get the Details

Contractors, see the references in the sections below for detailed descriptions of air sealing techniques and technologies.

Air Sealing Trouble Spots

- 1 Air Barrier and Thermal Barrier Alignment
- 2 Attic Air Sealing
- 3 Attic Kneewalls
- 4 Shaft for Piping or Ducts
- 5 Dropped Ceiling/Soffit
- 6 Staircase Framing at Exterior Wall
- 7 Porch Roof
- 8 Flue or Chimney Shaft
- 9 Attic Access
- 10 Recessed Lighting
- 11 Ducts
- 12 Whole-House Fan
- 13 Exterior Wall Penetrations
- 14 Fireplace Wall
- 15 Garage/Living Space Walls
- 16 Cantilevered Floor
- 17 Rim Joists, Sill Plate, Foundation, Floor
- 18 Windows & Doors
- 19 Common Walls Between Attached Dwelling Units

Air Sealing List

Each of these items is addressed on the following pages.

Air Barrier	Completion Guidelines
1. Air Barrier and Thermal Barrier Alignment	Air barrier is in alignment with the thermal barrier (insulation).
2. Attic Air Sealing	Top plates and wall-to-ceiling connections are sealed.
3. Attic Kneewalls	Air barrier is installed at the insulated boundary (kneewall transition or roof, as appropriate).
4. Duct Shaft/Piping Shaft and Penetrations	Openings from attic to conditioned space are sealed.
5. Dropped Ceiling/Soffit	Air barrier is fully aligned with insulation; all gaps are fully sealed.
6. Staircase Framing at Exterior Wall/Attic	Air barrier is fully aligned with insulation; all gaps are fully sealed.
7. Porch Roof	Air barrier is installed at the intersection of the porch roof and exterior wall.
8. Flue or Chimney Shaft	Opening around flue is closed with flashing, and any remaining gaps are sealed with fire-rated caulk or sealant.
9. Attic Access/Pull-Down Stair	Attic access panel or drop-down stair is fully gasketed for an air-tight fit.
10. Recessed Lighting	Fixtures are provided with air-tight assembly or covering.
11. Ducts	All ducts should be sealed, especially in attics, vented crawlspaces, and rim areas.
12. Whole-House Fan Penetration at Attic	An insulated cover is provided that is gasketed or sealed to the opening from either the attic side or ceiling side of the fan.
13. Exterior Walls	Service penetrations are sealed and air sealing is in place behind or around shower/tub enclosures, electrical boxes, switches, and outlets on exterior walls.
14. Fireplace Wall	Air sealing is completed in framed shaft behind the fireplace or at fireplace surround.
15. Garage/Living Space Walls	Air sealing is completed between garage and living space. Pass-through door is weather stripped.
16. Cantilevered Floor	Cantilevered floors are air sealed and insulated at perimeter or joist transition.
17. Rim Joists, Sill Plate, Foundation, and Floor	Rim joists are insulated and include an air barrier. Junction of foundation and sill plate is sealed. Penetrations through the bottom plate are sealed. All leaks at foundations, floor joists, and floor penetrations are sealed. Exposed earth in crawlspace is covered with Class I vapor retarder overlapped and taped at seams.
18. Windows and Doors	Space between window/door jambs and framing is sealed.
19. Common Walls Between Attached Dwelling Units	The gap between a gypsum shaft wall (i.e., common wall) and the structural framing between units is sealed.

1. Air Barrier and Thermal Barrier Alignment

The air barrier is in alignment with (touching) the thermal barrier (insulation).

Convective loops can form in wall cavities if there are gaps between the insulation and the air barrier. Convective loops (air movement within the wall cavities caused by temperature differences) will get cold air falling and hot air rising. This air movement reduces the effectiveness of the insulation and can pull in outside air and cause moisture problems. Arches, soffits, chases, and other design features create an uneven air barrier (drywall plane) that is difficult to insulate thoroughly. Expect the contractor to inspect these areas visually or with an infrared camera to make sure batts or blown insulation completely fill wall cavities.

Thermal and air barrier alignment is not an issue with insulation materials like spray foam or rigid foam that form an air barrier as well as thermal barrier, as long as they form a continuous air barrier from top to bottom and side to side. Spray foams should be sprayed to a consistent minimum depth across the area to be sealed and insulated. Rigid foam board that is serving as the air and thermal barrier should be taped at the seams with housewrap tape and glued with caulk at the edges to the wall framing, sill plate, or top plate. Blown cellulose and blown or batt fiberglass insulation will not stop air flow.



Figure 1.1. (left) Cut fiberglass batt insulation to fit around electrical boxes and wiring or pipes that run through the walls. Compressions like these ruin the batt's thermal alignment with walls and lessen its effectiveness.

Figure 1.2. (right) Install batts to fit smoothly and to completely fill wall and ceiling cavities. Here fiberglass batts completely fill joists of basement ceiling.

When To Do This

When replacing dry wall, replacing siding, adding an addition, adding insulation to attic or crawlspace or any time access is available.

Durability & Health

Convective loops in walls can pull in pollen, dust, and moisture. Walls that are not well insulated can provide a cold surface in wall cavities where warm indoor air can condense in winter and warm outdoor air can condense in the summer, encouraging mold growth in walls.

2009 IECC/2009 IRC Code

Requirement for New Construction and Additions

Air barrier and thermal barrier

- Exterior thermal envelope insulation for framed walls is installed in substantial contact and continuous alignment with building envelope air barrier.
- Breaks or joints in the air barrier are filled or repaired.
- Air-permeable insulation is not used as a sealing material.
- Air-permeable insulation is inside of an air barrier.

More Information

- Building America Best Practices
- U.S. Department of Energy 2009b
- U.S. Environmental Protection Agency 2008b

2. Attic Air Sealing

When To Do This

When replacing dry wall, replacing siding, adding an addition, adding insulation to attic, anytime you see cracks at the inside seam of the wall and ceiling. In vaulted ceilings, the ceiling-to-wall intersection can be accessed and sealed from the inside or from the outside when reroofing occurs.

Durability & Health

Heat moves from high-temperature regions to low-temperature regions. The warmer the air, the more water vapor it can carry with it. If warm, moist air gets into a cold attic through leaks in the home's thermal envelope, it can condense on rafters and other solid surfaces, which may lead to water damage and mold growth.

2009 IECC/2009 IRC Code

Requirement for New Construction and Additions

Ceiling/attic

Air barrier in any dropped ceiling/soffit is substantially aligned with insulation and any gaps are sealed.

More Information

- Building America Best Practices
- Lstiburek 2010
- U.S. Environmental Protection Agency 2008a
- U.S. Environmental Protection Agency 2008c

Top plates and wall-to-ceiling connections are sealed.

Good air-sealing and a continuous air barrier between the attic and the home's conditioned (living) space are important not only to save energy and reduce fuel bills, but also to prevent moisture problems in the attic. Sealing holes in the attic makes chimneys and flues work better because a leaky attic ceiling acts like a chimney and will compete with the real chimney for air. Air sealing the leaky attic ceiling also reduces the house's "suction" (or stack effect) so less contaminants are drawn up into the house from the ground such as radon and other soil gases (Lstiburek 2010).

On the inside of the home, the ceiling drywall can serve as an air barrier. Visible cracks at the seam of the wall and ceiling can be taped, mudded, and painted or filled with paintable caulk, such as silicon latex. Your contractor can determine where leaks are with an infrared camera, by feeling for air flow, or by inspecting the attic insulation. Dirty insulation is an indication that air is flowing through the insulation and pulling dust with it.

Your contractor may pull back or scoop out the insulation to apply caulk, spray foam, or other sealant where the walls meet the attic floor. Other places in the attic that often are big sources of air leaks are soffits (dropped-ceiling areas, duct chases, plumbing chase), behind or under attic kneewalls, around recessed can lights, around flue pipes, around ducts, and at attic hatches (see strategy #3, #4, #5, #8, #9, #10, and #11).

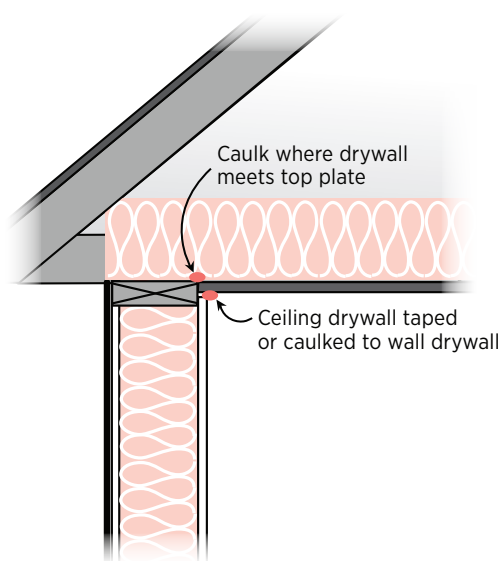

Figure 2.1. Seal the wall drywall to the top plate and ceiling drywall.

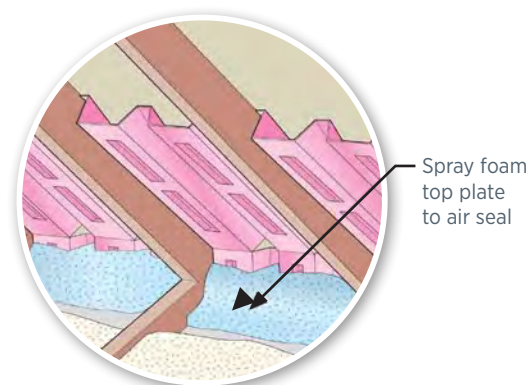

Figure 2.2. Pull back insulation to seal drywall to top plate with spray foam, caulk, or other sealer (Lstiburek 2010).

3. Attic Kneewalls

Air barrier is installed at the insulated boundary (kneewall transition or roof, as appropriate).

Kneewalls, the sidewalls of finished rooms in attics, are often leaky and uninsulated. Your contractor can insulate and air seal these walls in one step by covering them from the attic side with sealed rigid foam insulation. Your contractor can plug the open cavities between joists beneath the kneewall with plastic bags filled with insulation or with pieces of rigid foam. Another option is to apply rigid foam to the underside of the rafters along the sloped roof line and air seal at the top of the kneewall and the top of the sidewall, which provides the benefit of both insulating the kneewall and providing insulated attic storage space.

Doors cut into kneewalls should also be insulated and airsealed by attaching rigid foam to the attic side of the door, and using a latch that pulls the door tightly to a weather-stripped frame.

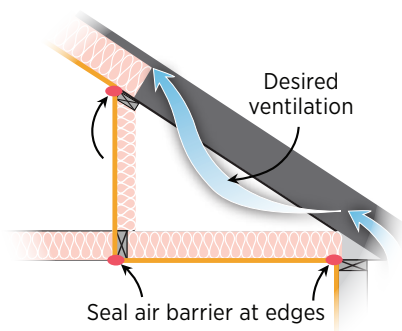

Figure 3.1. Insulate and air seal the kneewall itself, as shown, or along the roof line (Source: DOE 2000a).



Figure 3.2. Air seal floor joist cavities under kneewalls by filling cavities with fiberglass batts that are rolled and stuffed in plastic bags (as shown here) or use rigid foam, OSB, or other air barrier board cut to fit and sealed at edges with caulk.

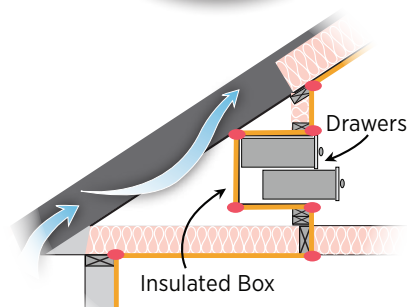

Figure 3.3. Build an airtight, insulated box around any drawers or closets built into attic knee walls that extend into uninsulated attic space. Insulate along air barrier (shown in yellow on drawing) or along roof line with rigid foam (Source: Iowa Energy Center 2008).

When To Do This

Any time you have access to kneewalls.

Durability & Health

If warm moist air gets into a cold attic through leaks in the home's thermal envelope, it can condense on rafters and other solid surfaces, which may lead to water damage and mold growth.

2009 IECC/2009 IRC Code

Requirement for New Construction and Additions

Ceiling/attic

Attic access (except unvented attic), kneewall door, or drop down stair is sealed.

More Information

- Building America Best Practices
- Iowa Energy Center 2008
- Lstiburek 2010
- U.S. Department of Energy 2000a
- U.S. Environmental Protection Agency 2008a
- U.S. Environmental Protection Agency 2008b
- U.S. Environmental Protection Agency 2008c

4. Duct Shaft/Piping Shaft and Penetrations

Openings from attic to conditioned space are sealed.

When To Do This

Any time you have access.

Durability & Health

HVAC, plumbing, and wiring chases can bring conditioned air into attics, leading to condensation and mold problems. They can also connect crawlspaces and living spaces bringing soil gases into the home.

2009 IECC/2009 IRC Code

Requirement for New Construction and Additions

Shafts, penetrations

Duct shafts, utility penetrations, knee walls and flue shafts opening to exterior or unconditioned space are sealed.

More Information

- Building America Best Practices
- Iowa Energy Center 2008
- U.S. Environmental Protection Agency 2008a
- U.S. Environmental Protection Agency 2008c
- House Energy 2009

Any chases, shafts, or building cavities that contain piping or wiring can serve as links between conditioned and unconditioned space. Your contractor can inspect these areas and close the gaps with caulk, spray foam, and blocking material (pieces of rigid foam, plywood, or oriented strand board cut to fit and sealed in place with spray foam). Furnace flues require high-temperature-rated sealing materials.

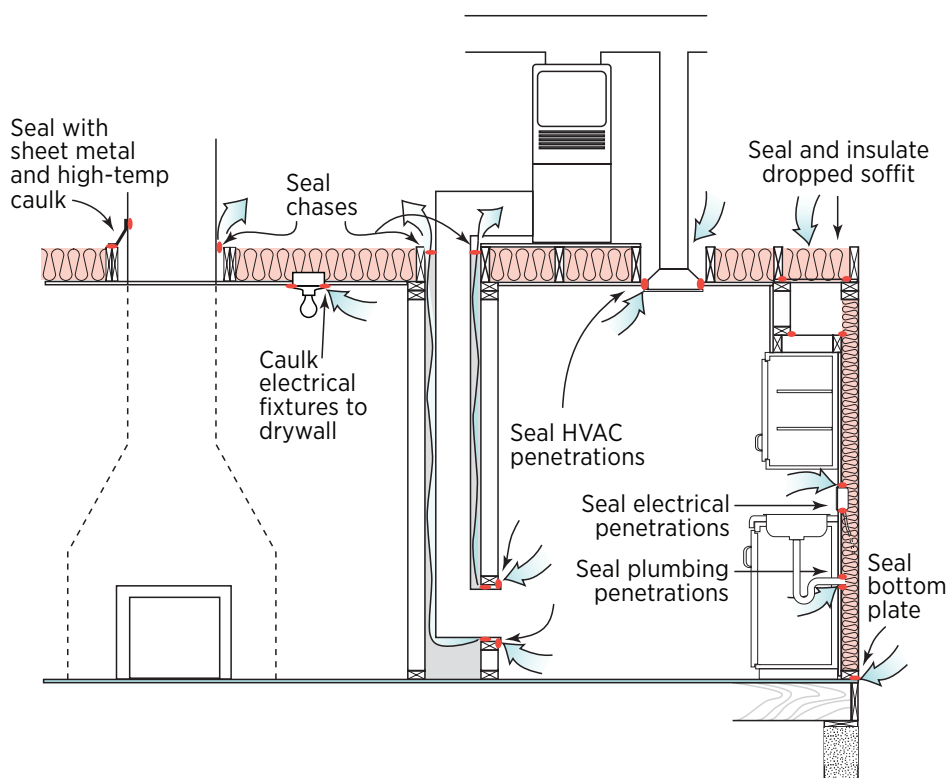

Figure 4.1. Seal attic and wall penetrations associated with mechanical ventilation systems, electrical chase openings, and dropped soffits (Source: DOE 2000a).

5. Dropped Ceiling/Soffit

Air barrier is fully aligned with insulation; all gaps are fully sealed.

Soffits (dropped ceilings) found over kitchen cabinets or sometimes running along hallways or room ceilings as duct or piping chases are often culprits for air leakage. Your contractor will push aside the attic insulation to see if an air barrier is in place over the dropped area. If none exists, the contractor will cover the area with a piece of rigid foam board, sheet goods, or reflective foil insulation that is glued in place and sealed along all edges with caulk or spray foam, then covered with attic insulation. If the soffit is on an exterior wall, sheet goods or rigid foam board should be sealed along the exterior wall as well. If the soffit contains recessed can lights, they should be rated for insulation contact and airtight (ICAT) or a dam should be built around them to prevent insulation contact.

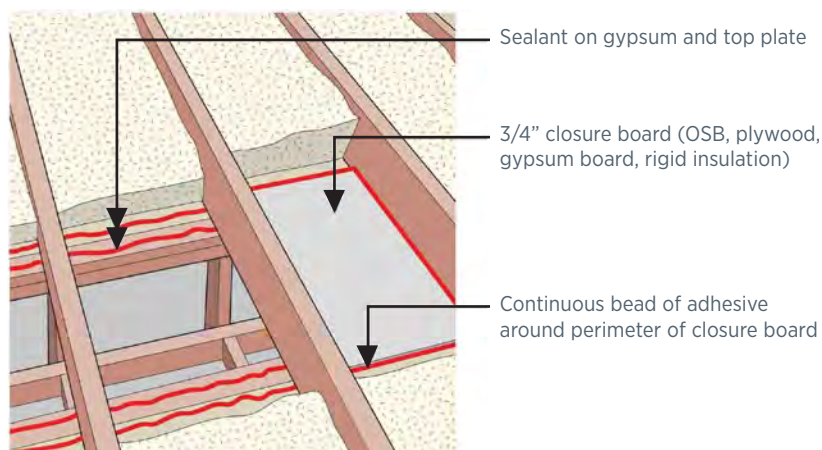

Figure 5.1. Place a solid air barrier over soffits as follows: pull back existing insulation; cover area with air barrier material (gypsum, plywood, OSB, rigid foam, etc.); seal edges with caulk; cover with insulation (Lstiburek 2010).

When To Do This

Any time, if attic construction allows access to area above soffits.

Durability & Health

If warm moist air gets into a cold attic through leaks in the home's thermal envelope, it can condense on solid surfaces, which may lead to water damage and mold growth.

2009 IECC/2009 IRC Code

Requirement for New Construction and Additions

Ceiling/attic

Air barrier in any dropped ceiling/soffit is substantially aligned with insulation and any gaps are sealed.

More Information

- Building America Best Practices
- Iowa Energy Center 2008
- Lstiburek 2010
- U.S. Environmental Protection Agency 2008a
- U.S. Environmental Protection Agency 2008b
- U.S. Environmental Protection Agency 2008c

6. Staircase Framing at Exterior Wall/Attic

When To Do This

Any time.

Durability & Health

Uninsulated exterior walls with no air barriers present a cold surface where condensation and mold can form.

2009 IECC/2009 IRC Code

Requirement for New Construction and Additions

Air barrier and thermal barrier

- Exterior thermal envelope insulation for framed walls is installed in substantial contact and continuous alignment with building envelope air barrier.
- Air-permeable insulation is inside of an air barrier.

More Information

- Building America Best Practices
- U.S. Environmental Protection Agency 2008c
- House Energy 2009

Air barrier is fully aligned with insulation; all gaps are fully sealed.

If the area under the stairs is accessible, look to see if the inside wall is finished. If not, have your contractor insulate it, if needed, and cover it with a solid sheet product like drywall, plywood, oriented strand board, or rigid foam insulation. Then, your contractor can caulk the edges and tape the seams to form an air-tight barrier. Stairs should be caulked where they meet the wall.

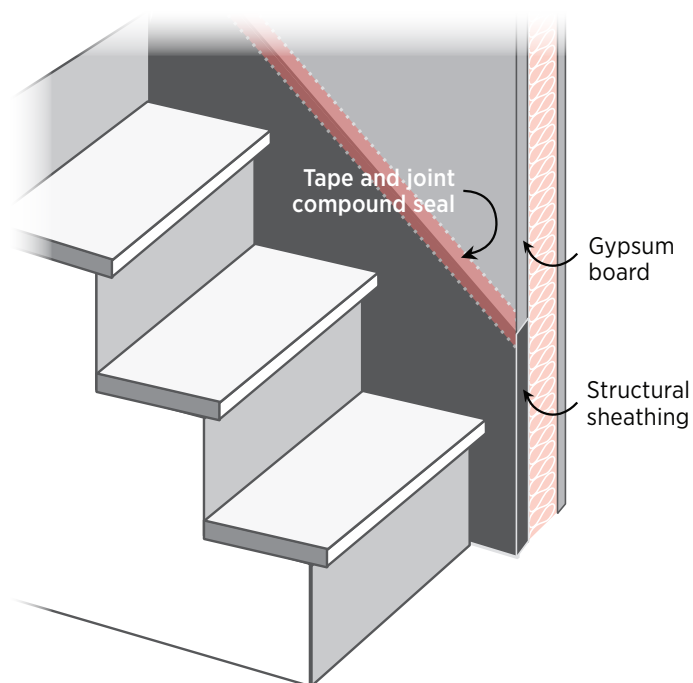

Figure 6.1. Install an air barrier and air sealing on exterior walls behind stairs. If the area behind the stairs is inaccessible, caulk stairs where they meet the wall. Use caulk if the area is already painted; use tape and joint compound if area will be painted.

7. Porch Roof

Air barrier is installed at the intersection of the porch roof and exterior wall.

If a test-in inspection identifies air leakage at the wall separating the porch from the living space, the contractor will investigate to see if the wall board is missing or unsealed. If this is the case, the contractor will install some type of wall sheathing (oriented strand board, plywood, rigid foam board) cut to fit and sealed at the edges with spray foam. Your contractor will also make sure this wall separating the attic from the porch is fully insulated.

Studies Show

Steven Winter Associates, a Building America research team lead, used a blower door test and infrared cameras to investigate high-energy bill complaints at a 360-unit affordable housing development and found nearly twice the expected air leakage. Infrared scanning revealed an air leakage path on an exterior second-story wall above a front porch. Steven Winter Associates found that, while the wall between the porch and the attic had been insulated with unfaced fiberglass batts, wall board had never been installed. The insulation was dirty from years of windwashing as wind carried dust up through the perforated porch ceiling, through the insulation, into the attic and into the wall above. Crews used rigid foam cut to fit and glued in place with expandable spray foam to seal each area. Blower door tests showed the change reduced overall envelope leakage by 200 CFM₅₀. At a cost of \$267 per unit, this fix resulted in savings of \$200 per year per unit, for a payback of less than two years.



Figure 7.1. When researchers pulled back the porch ceiling, they found the wall board was missing so nothing was covering the insulation on this exterior wall. An air barrier of rigid foam board was put in place with spray foam (Source: Moriarta 2008).

When To Do This

Any time, if porch wall is accessible, either from the attic or from the porch.

Durability & Health

Cold surfaces in the exterior wall encourage condensation and mold. If the air barrier is missing, wind can carry dust and pollen into the living space.

2009 IECC/2009 IRC Code

Requirement for New Construction and Additions

Air barrier and thermal barrier

- Exterior thermal envelope insulation for framed walls is installed in substantial contact and continuous alignment with building envelope air barrier.
- Breaks or joints in the air barrier are filled or repaired.
- Air-permeable insulation is inside of an air barrier.

More Information

- Building America Best Practices
- Moriarta 2008
- U.S. Environmental Protection Agency 2008b

8. Flue or Chimney Shaft

When To Do This

Any time the flue pipe is accessible in the attic.

Durability & Health

Use the right sealing products and techniques to keep flammable materials from touching hot flues.

2009 IECC/2009 IRC Code
Requirement for New Construction and Additions

Shafts, penetrations

Duct shafts, utility penetrations, knee walls and flue shafts opening to exterior or unconditioned space are sealed.

More Information

- Building America Best Practices
- U.S. Environmental Protection Agency 2008a
- U.S. Environmental Protection Agency 2008c

Opening around flue is closed with flashing, and any remaining gaps are sealed with fire-rated caulk or sealant.

There are often gaps around chimneys, furnaces, and water heater flues that allow conditioned air to flow up into the attic. Your contractor can seal this gap with lightweight aluminum flashing (sheet metal) and special high-temperature (heat-resistant) caulk. A

metal dam should be used to keep insulation away from the flue. The same technique is used for masonry chimneys.



Figure 8.1.

Step 1: Cut aluminum flashing to fit around flue.



Figure 8.2.

Step 2: Seal flashing to pipe with high-temperature caulk.

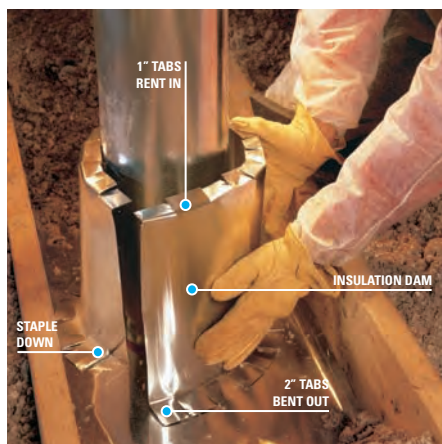

Figure 8.3.

Step 3: Form an insulation dam to keep the insulation from coming into contact with the flue pipe.

(Source: EPA 2008a)

9. Attic Access/Pull-Down Stair

Attic access panel or drop-down stair is fully gasketed for an air-tight fit.

A home's attic access, which could be an attic hatch, pull-down stairs, or a kneewall door, can leak a lot of heated or cooled air into the attic if it is not sealed properly.

Your contractor can add weather stripping either to the frame or panel of the attic access and may install latch bolts to ensure a tighter seal. The hatch lid, stairs, or door should be insulated too.

If you are planning to add an attic access, consider the location. An access hatch or pull-down stairs that is located in an unconditioned part of the house, such as a garage, covered patio, or porch, does not necessarily need to be air sealed or insulated. If your hatch connects conditioned space like a bedroom, hallway, or closet to an unconditioned attic, your contractor will check for air leakage.

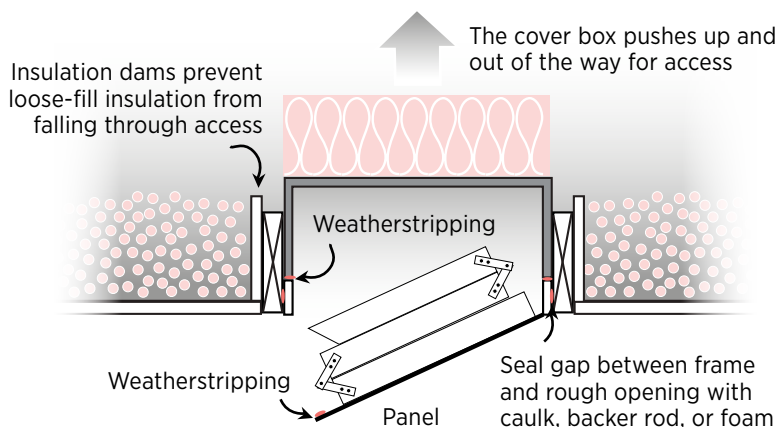

Figure 9.1. Insulate and air seal the attic access hatch cover.

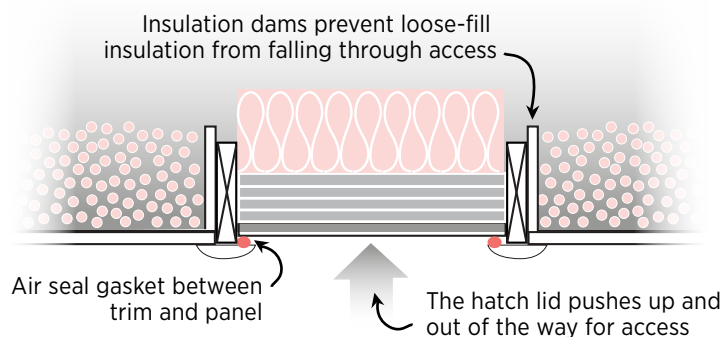

Figure 9.2. Insulate and air seal the pull-down attic stair.

When To Do This

Any time.

Durability & Health

Air sealing the attic access will minimize the amount of moisture-laden air that escapes into the attic reducing the risk of mold in the attic.

2009 IECC/2009 IRC Code

Requirement for New Construction and Additions

Ceiling/attic

Attic access (except unvented attic), knee wall door, or drop down stair is sealed.

More Information

- Building America Best Practices
- U.S. Department of Energy 2000b
- U.S. Department of Energy 2009a
- U.S. Environmental Protection Agency 2008a

10. Recessed Lighting

When To Do This

Replace old uninsulated can fixtures when changing lighting fixtures; can caulk any time.

Durability & Health

Non-airtight recessed can fixtures can allow heated air to escape to attic during winter, carrying moisture that can condense in a cool attic. They can also draw hot attic air into the home in summer, pulling dust and insulation particles into the home.

2009 IECC/2009 IRC Code

Requirement for New Construction and Additions

Recessed lighting

Recessed light fixtures are airtight, IC rated, and sealed to drywall. Exception: fixtures in conditioned space.

More Information

- Building America Best Practices
- ASTM 1991
- McCullough and Gordon 2002

Fixtures are provided with air-tight assembly or covering.

Recessed downlights are the most popular home lighting fixture in the United States. Older model recessed can fixtures are energy intensive in three ways—they are not approved for insulation contact so insulation has to be kept at least 3 inches away all the way around, leaving about 1 square foot of uninsulated ceiling space. Most are using incandescent bulbs that use 3 to 5 times the power of fluorescents and add to air-conditioning loads. Third, the cans are not airtight, so they allow conditioned air to escape from the living area into unconditioned spaces such as attics.

If your home has non-airtight fixtures, you can have a contractor replace the whole fixture with insulation contact-rated, air-tight (ICAT) fixtures, or caulk around the fixture, under the trim ring if caulking from inside the home. Other alternatives are to install the recessed cans in an air-sealed dropped soffit or to use surface-mounted fixtures instead. After air sealing, replace any incandescent lights in the recessed lighting fixture with low-wattage CFL or LED lamps.

Studies Show

Old, leaky recessed cans are like a hole in the ceiling, only worse. Old recessed cans with incandescent bulbs can pull 3 to 5 times as much air as a hole the same size, thanks to the “stack effect”—the heat inside the can pulls air from the house up into the attic. Replacing a leaky can with an ICAT (insulation contact-rated, air-tight) recessed downlight would save a Phoenix, AZ, homeowner \$1.56 per year in cooling costs or a Minneapolis, MN, homeowner \$3.57 per year in heating costs (these savings don’t even include the possible energy savings of CFL bulbs over incandescent bulbs) (McCullough and Gordon 2002).

Figure 10.1. (left) Replace old, leaky can fixtures with insulated, airtight recessed light fixtures and caulk them where the housing meets the drywall.

Figure 10.2. (right) Seal cans to prevent heated and cooled air from leaking into attics as shown in this infrared camera image.

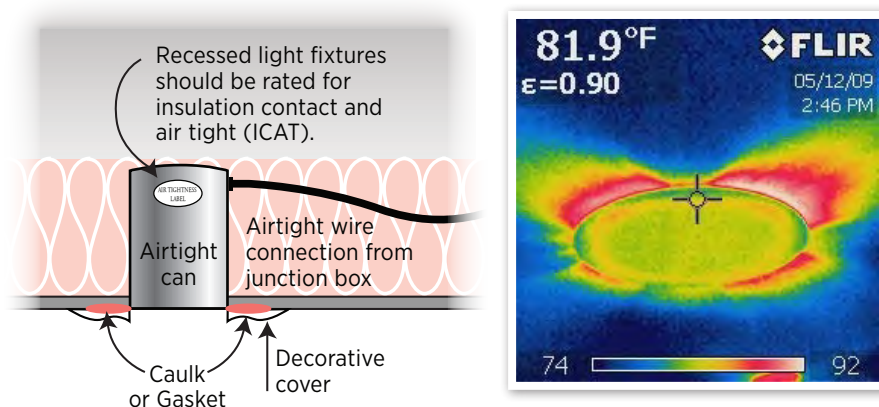

11. Ducts

All ducts should be sealed, especially in attics, vented crawlspaces, and rim areas.

Repairing leaking ducts can yield big energy improvements. Duct sealing contractors often find more than just a few leaks: duct tape dries and falls away; ducts may have been torn or crumpled by other trades during installation; and poorly hung ducts can have bends and kinks that prevent air from flowing through them. It is not uncommon to find one or more ducts completely disconnected from their register.

If return ducts in the heating and air-conditioning system have holes, they can draw in hot attic air or cold outside air. As a result, the system must work harder and use more energy to heat and cool the inside of the house. In older homes, wall cavities and floor joist cavities are sometimes used as return “ducts” to bring air from the return registers back to the air handler unit, but these building cavities are rarely air sealed.

A heating and cooling equipment contractor may

- Inspect the duct system, including the attic and crawlspace.
- Evaluate the system’s supply and return air flow.
- Repair damaged and disconnected ducts.
- Seal all leaks and connections with mastic (a thick sealant painted on duct joints).
- Seal all registers and grills to the ducts.
- Insulate ducts in unconditioned areas (like attics, crawlspaces, and garages) with duct insulation that has an R-value of 6 or higher.
- Replace the filter as part of any duct system improvement.
- Retest air flow after repairs are completed.
- Ensure there is no backdrafting of gas or oil-burning appliances, and conduct a combustion safety test after ducts are sealed.

When To Do This

Whenever and wherever ducts are accessible.

Durability & Health

Unsealed ducts can draw in dust, moisture, and contamination from unconditioned spaces in the home. Broken ducts can be a pathway for pests.

2009 IECC/2009 IRC Code

Requirement for New Construction and Additions

HVAC register boots

HVAC register boots that penetrate building envelope are sealed to subfloor or drywall.

More Information

- Building America Best Practices
- Building Science Corporation 2006
- Building Science Corporation 2009d
- Cummings et al. 1990
- Granade et al. 2009
- Jump and Modera 1994
- Karins et al. 1997
- ORNL
- Sherman et al. 2000
- U.S. Environmental Protection Agency 2008a
- U.S. Environmental Protection Agency 2009a



Figure 11.1. Paint mastic (a thick, goeey substance) on to the duct seams and joints. (Photo source: Habitat for Humanity Lakeland FL).

DOE studies show duct tape fails within months (Sherman et al. 2000).

Studies Show

In a study of energy-efficient measures, DOE’s Energy Information Administration reported that sealing the ducts yielded by far the greatest energy savings of the 12 measures studied, at the lowest cost (Granade et al. 2009). In a DOE study of 100 homes in Phoenix, Arizona, sealing ducts cut leakage by 30%, saving homeowners \$80 per year. A study of 24 Florida homes found air-conditioning energy use was reduced by 18% after duct repairs were made (Cummings et al. 1990). A study of a retrofit project involving 25 apartments in New York found that sealing the HVAC ducts cut airflow leakage by 92 CFM for supply ducts and 223 CFM for return ducts with a simple payback of 3 to 4 years (Karins et al. 1997). Research on six homes in the southwest indicated that 30% to 40% of the thermal energy delivered to the ducts passing through unconditioned spaces is lost through air leakage and conduction through the duct walls. Sealing and insulating the ducts cut overall duct leakage approximately 64% (Jump and Modera 1994).

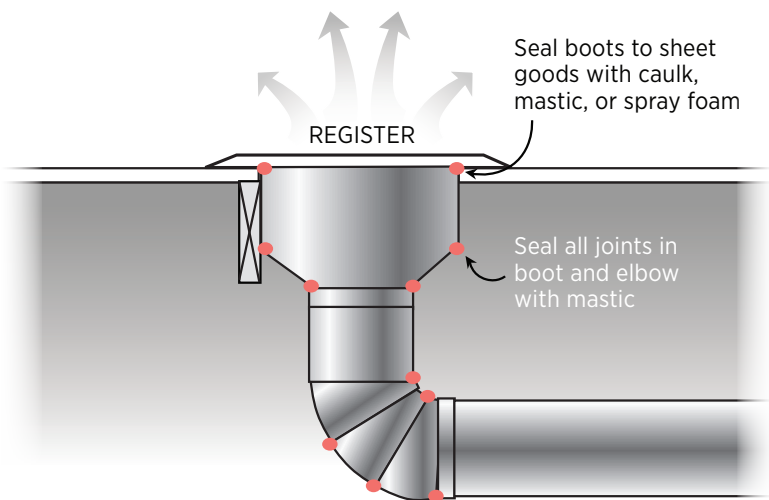

Figure 11.2. Mastic seal all supply and return air ducts.

12. Whole-House Fan Penetration at Attic

An insulated cover is provided that is gasketed or sealed to the opening from either the attic side or ceiling side of the fan.

A whole house fan is a fan installed in the ceiling to help quickly cool the house by drawing air into the house through open windows on summer mornings and evenings when the outside temperature is lower than the indoor temperature. Ideally, the air should be ducted to exhaust outside, not into the attic space. During the winter months (and in summer when the air conditioner is running), the whole house fan is not used. At those times, it represents a potential energy loss because it is essentially a large, uninsulated hole in the ceiling. Since standard fan louvers do not insulate or seal tightly, a cover should be constructed or purchased to air seal and insulate this hole from the attic side, the house side, or in case of very hot or cold weather, both sides. Homeowners must remember to remove cover(s) before operating the fan and to replace cover(s) during seasons when the fan is not in use.

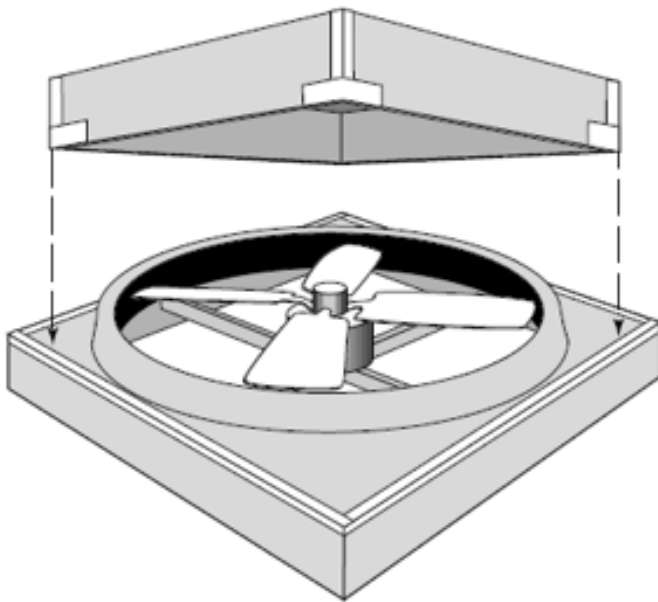

Figure 12.2. Install a removable, insulating, air-sealing cover over your whole house fan (Source: Southface Energy Institute 1999).

When To Do This

When a whole house fan is installed.

Durability & Health

A whole house fan can pull large quantities of air from the home and, if windows are not open, it can easily backdraft a fireplace or combustion appliance located in the home or attic. Some localities will not permit a whole house fan to be installed if a furnace is located in the attic or if there is a combustion appliance in the home that derives its combustion air from either the attic or the inside of the home unless the homeowner 1) encloses the combustion appliance so that it obtains combustion air from outside the home; 2) ducts the whole house fan directly to the exterior; or 3) provides a switching device that allows only one of the appliances (fan or furnace) to be on at a time (Davis 2001). The whole house fan should be ducted to the outside or adequate ventilation must be provided in the attic to prevent the attic from being overpressurized and pushing attic dust into the house.

2009 IECC/2009 IRC Code

Requirement for New Construction and Additions

Shafts, penetrations

Duct shafts, utility penetrations, knee walls and flue shafts opening to exterior or unconditioned space are sealed.

More Information

- Building America Best Practices
- Davis 2001
- DOE 1999
- Southface Energy Institute 1999

13. Exterior Walls

When To Do This

Seal wall penetrations whenever accessible. Sill- and top-plate penetrations may only be accessible during construction of new walls or additions or when exterior or interior wall sheathing is being replaced. Electrical switches and outlets can be accessed any time.

Durability & Health

Unsealed penetrations can be a pathway for dust and pests to enter the home. Penetrations through the top plate must be sealed if the top plate is in the plane of an intended air, smoke, or fire separation (BSC 2009).

2009 IECC/2009 IRC Code

Requirement for New Construction and Additions

Shafts, penetrations

Duct shafts, utility penetrations, knee walls and flue shafts opening to exterior or unconditioned space are sealed.

Shower/tub on exterior wall

Showers and tubs on exterior walls have insulation and an air barrier separating them from the exterior wall.

Electrical/phone box on exterior walls

Air barrier extends behind boxes or air sealed-type boxes are installed.

More Information

- Building America Best Practices
- Building Science Corporation 2006
- Building Science Corporation 2009e
- U.S. Environmental Protection Agency 2008a

Service penetrations are sealed.

Your exterior walls may have a surprising number of holes in them—for plumbing pipes and vents, electrical wires and conduits, electrical fixtures, clothes dryer ducts, and exhaust fans. Holes may also have been drilled through the top and bottom plates; ideally, these were caulked and sealed during construction as these areas are nearly impossible to get to later, unless drywall or exterior sheathing is being replaced. Your contractor will caulk penetrations through walls from the exterior and interior. An ideal time to seal the drywall to the subfloor is when walls are being painted and baseplate trim is removed (just pull back the carpet) or when floor covering is being replaced.

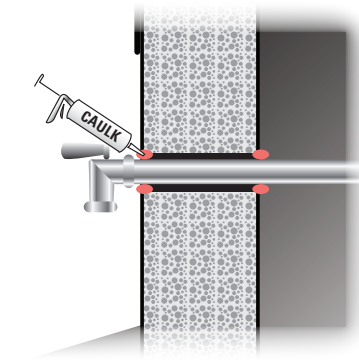

Figure 13.1. Caulk all plumbing penetrations through exterior walls.

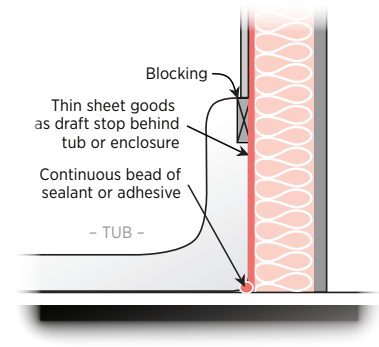

Figure 13.2. If you are remodeling a bathroom make sure you seal and insulate behind the tub or shower, especially if it is on an exterior wall.

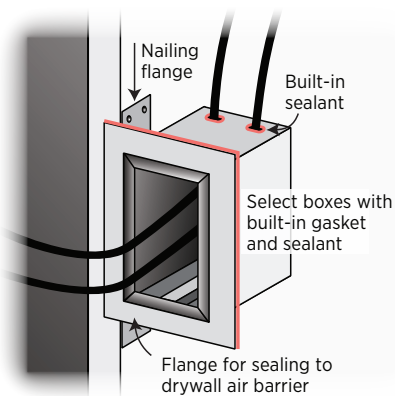

Figure 13.3. Seal all electric outlets and switches with foam sealant, or select boxes with built-in sealant or gaskets. Install foam gaskets between electrical outlets or switches and their coverplates, and insert plastic “child-safety” plugs into the outlets to further block airflow.

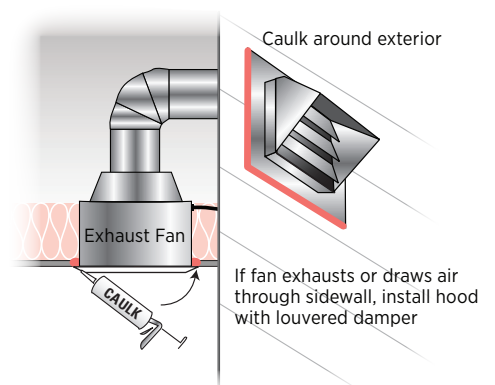
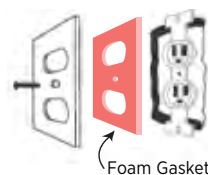

Figure 13.4. Caulk around exhaust fans at the ceiling and exterior wall. Also caulk around exterior outlets and light fixtures.

14. Fireplace Wall

Air sealing is completed in framed shaft behind the fireplace or at fireplace surround.

Fireplaces have many potential areas of air leakage. Air sealing and insulation are often missing from the enclosure that forms a prefabricated fireplace. There are often unsealed air gaps around the flue and the surround. Flue dampers are not airtight, allowing air to escape up the chimney even when no fire is burning in the fireplace (BSC 2009). A fireplace can actually waste more heat than it creates (Iowa Energy Center 2008).

Even if you close the fireplace damper and it leaks just a little, a lot of warm air from your home will be drawn up the chimney and be replaced by cold air leaking into the house. If you use the fireplace, follow these air sealing tips: (Iowa Energy Center 2008)

- Every year, have the fireplace and chimney inspected and cleaned by a certified chimney sweep.
- Check the seal of the flue damper with an incense stick or piece of burning paper. Seal around the damper assembly with refractory cement, but don't seal the damper closed. Replace warped or missing dampers.
- Use a removable plug like a chimney balloon that you insert in the chimney above the damper and inflate to plug air leaks when you're not using the fireplace. If you forget to remove it before starting a fire, it will react to the heat and quickly deflate.
- Install tight-fitting glass doors.
- Make a tight-fitting air barrier to cover the fireplace opening when not in use from rigid board insulation and plywood edged with pipe insulation (Iowa Energy Center 2008).
- Consider installing a sealed, natural gas or propane fireplace insert. These inserts are sealed combustion and do away with door and flue leaks.

Studies Show

Studies have shown that fireplace dampers are often left open. One study showed found 80% of fireplace dampers were inadvertently left open (Tyrol and Pate 2007). In a DOE-funded study of 56 new homes in Arkansas with gas or wood fireplaces, the fireplaces accounted for 5.3% of total house air leakage (Brown 1999).

When To Do This

At any time.

Durability & Health

An open, unsealed fireplace carries risks of backdrafting carbon monoxide, smoke, and ash into the home. A sealed fireplace with its own combustion air intake is preferred. Homes that use gas or wood fireplaces should have carbon monoxide detectors.

2009 IECC/2009 IRC Code

Requirement for New Construction and Additions

Fireplace

Fireplace walls include an air barrier.

More Information

- Building America Best Practices
- Brown 1999
- Building Science Corporation 2009a
- Dalicieux and Nicolas 1990
- Iowa Energy Center 2008
- Tyrol and Pate 2007
- U.S. Environmental Protection Agency 2008a

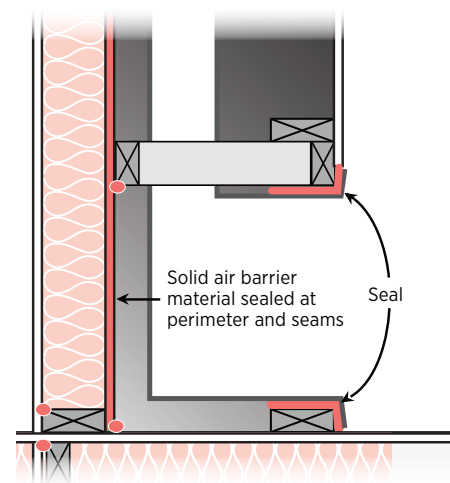

Figure 14.1. Air seal the enclosure surround and flue.

15. Garage/Living Space Walls

Air sealing is completed between garage and living space. Pass-through door is weather stripped.

When To Do This

At any time.

Durability & Health

Garages often contain harmful chemicals and gases that must be kept out of the living space by thorough air sealing of any common walls and ceilings.

2009 IECC/2009 IRC Code

Requirement for New Construction and Additions

Garage separation

Air sealing is provided between the garage and conditioned spaces.

More Information

- Building America Best Practices
- Aspen Publishers 2000
- Iowa Energy Center 2008
- University of Illinois Extension Office
- U.S. Environmental Protection Agency 2010

For occupant health and safety, the garage should be completely air sealed from the living areas of the house. When the garage is beneath a second-story living space, the gaps created by the floor joists spanning both the living space and the garage must be blocked off and sealed. If the air handler for a central furnace must be located in the garage, it should be in an air-sealed closet with its own air intake, so that it is not drawing garage air to circulate through the house.

If you have an attached garage, expect your contractor to visually inspect for cracks or improper sealing of the walls separating the garage from the home, to test the seal tightness of doors linking the garage with the rest of the home, to test carbon monoxide levels in the house, to measure interface leakage between the garage and house, and to determine what size garage exhaust fan, if any, is advisable.

Steps to a Healthier Garage – *eliminate, isolate, ventilate.*

Keep in mind the following:

1. Your very best option is to build a detached garage.
2. If that is not possible, try removing or isolating pollutants. Park cars, mowers, etc., outside. Do not let cars or mowers idle in the garage (and of course never start them with the garage door closed). Start gas-powered mowers, leaf blowers, etc., outside. Store paints, solvents, and other chemicals in tight containers.

Your contractor can assist you with the following recommendations:

3. Seal all penetrations through the common wall and ceiling. Use gaskets, airtight drywall technique, etc., to make the common wall and ceiling airtight.
4. Seal ducts located in the garage. (Avoid locating supply or return registers in the garage when remodeling.)
5. Install a self-closing, insulated, metal, fire-rated door with a good weather seal between the living space and the garage.
6. Install a passive roof vent to keep the garage at a negative pressure in relationship to the house. If needed, install a timed exhaust fan that vents to the outside.

Studies Show

In a field study of 12 homes in Anchorage, Alaska, researchers found that carbon monoxide (CO) from car starts in the garages entered all but 1 of the 12 houses. Four of the homes came close to the EPA CO exposure limit and, in one case, exceeded it (Aspen Publishers 2000). Noted the author: "In all but one case, the house was operating under negative pressure relative to the garage due to the stack effect. In other words, the house was sucking CO and other airborne contaminants through the common walls and ceilings." The researchers found high CO in homes where furnace ductwork was located in the garage and where the garage was located under occupied space above. A study by Health Canada identified 150 different pollutants commonly found in garages. Preliminary results from 25 houses tested in that study found that an average of 13% of all infiltration into the houses was through the common wall between the garage and house. A Minnegasco study measured typical leakage at an even higher 25% (Aspen 2000).



15.2. Seal rim joists of the wall separating the house's living space from the garage with pieces of wall board and spray foam.

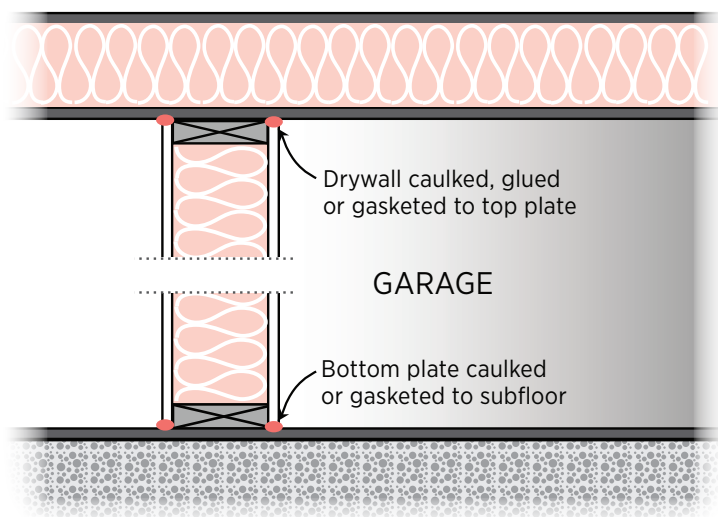

Figure 15.1. Finish the walls that separate the garage from the rest of the home with drywall that is sealed to the top and bottom plate with a bead of caulk.

16. Cantilevered Floor

When To Do This

When comfort complaints or high utility bills warrant it; if an infrared camera inspection reveals the cantilevered floor to be a source of high leakage.

Durability & Health

If a cantilever isn't properly air sealed and insulated, moist air from the home can pass into the cantilever floor cavity and condense on the coldest surface it finds—the backside of the sheathing or band joist—causing mold to grow there.

2009 IECC/2009 IRC Code

Requirement for New Construction and Additions

Floors (including above-garage and cantilevered floors)

Insulation is installed to maintain permanent contact with underside of subfloor decking. Air barrier is installed at any exposed edge of insulation.

More Information

- Building America Best Practices
- Lugano 1998
- U.S. Environmental Protection Agency 2008b

Cantilevered floors are air sealed and insulated at perimeter or joist transitions.

Cantilevered floors, second-story bump-outs, and bay windows are another area in the home that is often lacking proper air sealing. The floor cavity must be filled with insulation with good alignment (i.e., that is completely touching) the underside of the floor. The interior and exterior sheathing needs to be sealed at the framing edges. Blocking between floor joists should form a consistent air barrier between the cantilever and the rest of the house. Continuous sheathing, such as insulating foam sheathing, should cover the underside of the cantilever, and be air sealed at the edges with caulk.

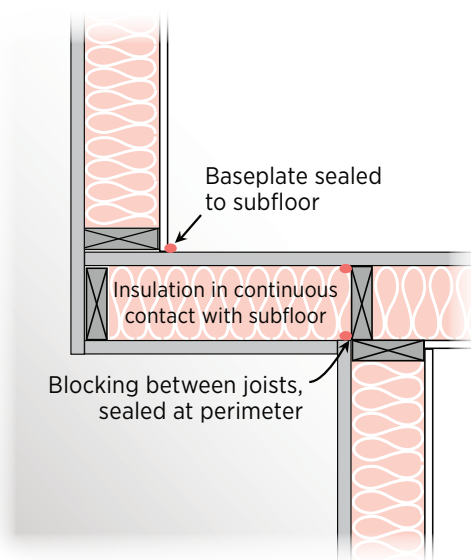

Figure 16.1. Block and air seal both the floor-to-upper wall junction and the floor-to-lower wall junction.

17. Rim Joists, Sill Plate, Foundation, and Floor

Rim joists are insulated and include an air barrier. Junction of foundation and sill plate is sealed. Penetrations through the bottom plate are sealed. All leaks at foundations, floor joists, and floor penetrations are sealed. Exposed earth in crawlspace is covered with Class I vapor retarder overlapped and taped at seams.

The rim joist (also called a band joist) is the horizontal beam that rests on top of the foundation wall or between floors. The floor joists are attached to or run parallel with it. Rim joists are a particularly troublesome area for air leakage. Several framing components (foundation wall and sill plate or top plate, rim joist, and subfloor above) need to be connected and sealed to form a continuous air barrier. Your contractor will inspect this area and, if needed, air seal and insulate along the joints where the floor joists meet the rim joist and the rim joist meets the subfloor. The rim joist can be air sealed and insulated with caulk and batt insulation, or rigid foam cut to fill the space between each floor joist and sealed in place with spray foam. Another option is to spray high- or low-density urethane foam at each joist bay to cover the foundation wall-top plate-rim joist-subfloor connections.

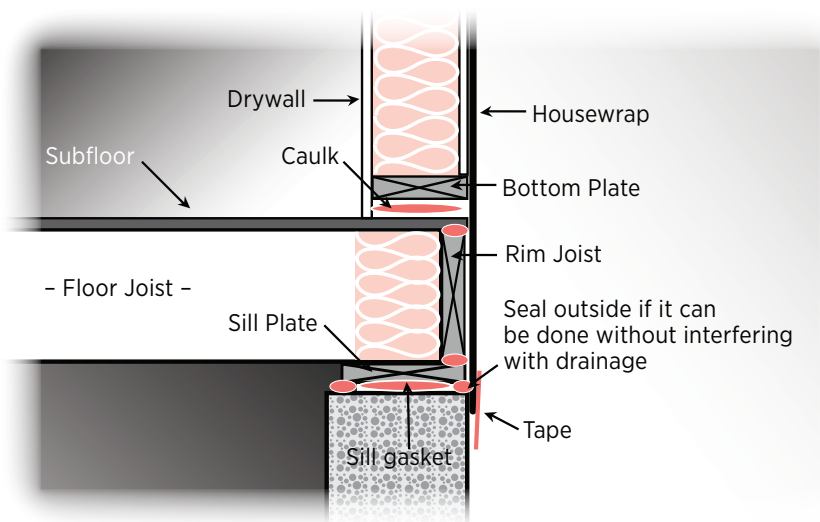

Figure 17.1. Use caulk or spray foam to air seal where the foundation wall meets the sill plate, where the sill plate meets the rim joist, and where the rim joist meets the subfloor.

When To Do This

Air sealing rim joists below the first floor can be done in conjunction with finishing the basement, when insulating the basement walls, or whenever an unsealed rim joist is accessible from inside. Plywood subfloor seams can be sealed when replacing flooring or replacing or installing insulation beneath the floor.

Durability & Health

The interior side of the rim joist is a cold surface in wintertime; condensation can form there if it is not properly insulated. A dirt crawlspace floor should be covered with a Class 1 vapor retarder (e.g., 6-mil polyethylene). If the home has an unvented crawlspace, the underside of the floor should be air sealed and a vent stack can be installed to minimize entry of soil gases into living space.

2009 IECC/2009 IRC Code

Requirement for New Construction and Additions

Walls

Junction of foundation and sill plate is sealed.

Corners and headers are insulated.

Rim joists

Rim joists are insulated and include an air barrier.

Crawlspace walls

Exposed earth in unvented crawlspaces is covered with Class I vapor retarder with overlapping joints taped.

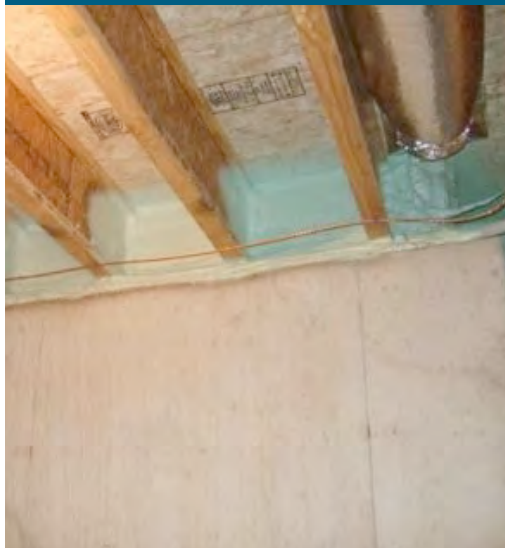

Figure 17.2. Spray foam along the basement rim joist to provide a complete air barrier connecting the foundation wall, sill plate, rim joist, and subfloor (Source: BSC 2009C).

Your contractor will seal the seams of the subfloor plywood panels if they are accessible. The contractor will also seal all holes that go through the basement ceiling to the floor above, such as holes for plumbing, HVAC ducts, and furnace vent pipes if the furnace is located in the basement.

If your house's foundation is a slab, your contractor can check for and seal air leaks where the sill plate meets the foundation. If your home has an unvented crawlspace your contractor will check the foundation for cracks and holes that may need sealing. The crawlspace access hatch should be weather stripped or gasketed. If the crawlspace floor has exposed earth, this should be covered with Class I vapor retarder with overlapping joints that are taped.

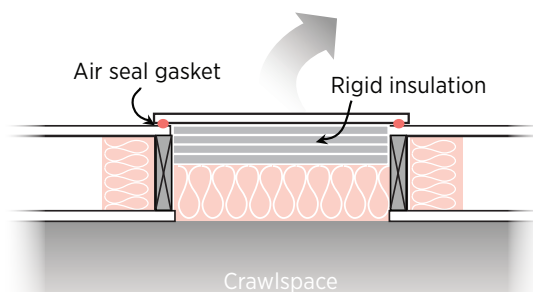

Figure 17.3. Air seal the crawlspace access hatch by installing a gasket or weather stripping around the hatch edges.

More Information

- Building America Best Practices
- Building Science Corporation 2009c
- Conbere and Fried 2006
- Braun 1995
- Building Science Corporation 2009e
- Lstiburek 2004a, b; 2006; 2008
- U.S. Department of Energy 2000a
- U.S. Environmental Protection Agency 2008b
- U.S. Environmental Protection Agency 2009b
- U.S. Environmental Protection Agency 2009c

Studies Show

One homeowner in Illinois had spent thousands of dollars re-siding his house with rigid foam insulation, adding insulation, upgrading his furnace, and replacing windows but his house was still drafty and his utility bills were still high. He called in a BPI-certified contractor who conducted several assessments including a blower door test of the whole house and individual rooms to determine where air was leaking. The blower door showed the home's air leakage was three times higher than preferred. The contractor recommended plugging leaks in the crawlspace and rim joists; adding joist insulation; air-sealing all plumbing, electrical, service, and duct penetrations; and insulating and air sealing the crawlspace access and attic hatch cover. The upgrades cost \$2,500 and saved the homeowner \$700 a year in energy costs (Conbere and Fried 2006).

18. Windows and Doors

Space between window/door jambs and framing is sealed.

When windows are installed in a new house, the rough opening (the space left for the window) is typically 1.5 to 2 inches larger than the window frame to give the installer room to install, plumb, and square the window. The same is true of doors. Your contractor can properly seal around the existing windows by removing the interior trim and filling the rough opening with non-expanding foam or backer rod and caulk. A simpler but more visible alternative is to leave the interior trim in place and seal around it with a clear silicone caulk or paintable latex caulk with silicone. Replace any cracked or loose panes. Consider replacing older, single-pane windows that show signs of leakage, water damage, or condensation with new double-pane windows installed with proper air sealing and flashing.

Windows and doors should be weather stripped. See the DOE Energy Savers website for a comprehensive description of different types of caulking and weather stripping material www.energysavers.gov/your_home/insulation_airsealing/index.cfm/mytopic=11260.

Older homes often have double-hung windows with chases hidden in the wall for counter weights. Access these chases by removing the side trim or by going through access ports along the sides of the window. If the window is replaced, the weight should be removed and the chases filled with insulation and sealed. If you have old windows with working pulleys, the pulley holes can be air sealed but kept usable with plastic caps called pulley seals. Doors should be self-closing and have a tight fitting sill.

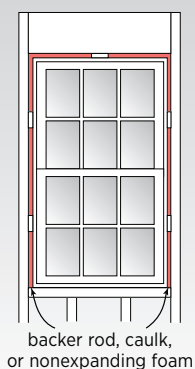

Figure 18.1. Use backer rod, caulk, or nonexpanding foam approved for windows and doors to fill the rough-in gap around doors and windows (DOE 2000).

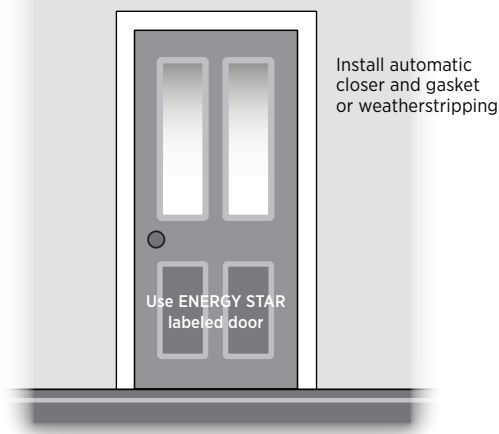

Figure 18.2. Install automatic closer and gasket or weatherstripping around doors. Caulk around trim.

When To Do This

Any time.

Durability & Health

More efficient windows may be less prone to condensation and related mold growth. Painted window sashes and frames in homes built before 1978 may contain lead-based paint; use a contractor experienced in lead removal.

2009 IECC/2009 IRC Code

Requirement for New Construction and Additions

Windows and doors

Space between window/door jambs and framing is sealed.

More Information

- Building America Best Practices
- Building Science Corporation 2009b
- Stovall et al. 2007
- U.S. Department of Energy 2000a
U.S. Department of Energy 2009c
- U.S. Environmental Protection Agency 2008b

Studies Show

A study conducted at Oak Ridge National Laboratory's Buildings Technology Center on window air sealing showed that windows with $\frac{3}{4}$ -inch rough-in gaps had an equivalent leakage area of 28.2 cm²/m². When the gap was caulked from the interior side of the wall, the equivalent leakage area was cut to 0.5 cm²/m² (Stovall et al. 2007).

19. Common Walls Between Attached Dwelling Units

When To Do This

Whenever common wall is accessible.

Durability & Health

Common walls between units are fire-rated and should be air sealed and properly blocked to minimize fire spread and entry of air, moisture, and pests.

2009 IECC/2009 IRC Code

Requirement for New Construction and Additions

Common wall

Air barrier is installed in common wall between dwelling units.

More Information

- Braun and Woods 1995
- Building Science Corporation 2009e
- U.S. Environmental Protection Agency 2008b

The gap between a gypsum shaft wall (i.e., common wall) and the structural framing between units is sealed.

Common walls between units in multi-family housing (e.g., townhouses, duplexes, and apartments) should be constructed as airtight assemblies for sound, smoke, fire, and air quality control. However, experience has shown that these common walls can often be significant sources of air and heat loss if gaps or cracks exist in the connections between each unit's walls. Your contractor can determine whether this is a significant source of air leakage in your home.

To reduce air leakage, this assembly should be air sealed at all boundaries. Your contractor will seal wood frame walls with fireproof spray foam (EPA 2008). Masonry block party walls, which form "chimneys" because of their porosity and open cores, can be air sealed with two-component urethane foam, which also reduces sound, odor transfer, and dust, insects, and moisture entry (Braun et al. 1995).

Because these walls are fire-rated assemblies for each unit, acceptable materials for air-sealing common walls can vary significantly around the country. Your contractor will confirm with local code officials which material is preferred for fire safety reasons, prior to retrofitting. The contractor will seal all plumbing penetrations through the drywall surface of common walls with fire-rated sealant materials (BSC 2009).



Figure 19.1. Seal air gaps between two framed common walls (Source: Energy Services Group, from EPA 2008)

References

- Aspen Publishers** 2000. "How Attached Garages Poison Our Indoor Air, And What Builders Can Do About It." in *Energy Design Update*, Volume 20, No. 12; December 2000 http://arkansasenergy.org/business_development/energy/files/Clearinghouse/How%20Attached%20Garages%20Poison%20Our%20Indoor%20Air.pdf
- ASTM** 1991. "Standard Test Method for Determining the Rate of Air Leakage through Exterior Windows, Curtain Walls, and Doors under Specified Pressure Differences across the Specimen." ASTM E283-91, West Conshohocken, Pennsylvania.
- Building America Best Practices, Volumes 1-9.** These Best Practices Guides from the U.S. Department of Energy provide building science guidance for builders of energy efficient homes in every U.S. climate zone. Available for free download at http://www1.eere.energy.gov/buildings/building_america/publications.html
- Braun, B. J. Hansen, and T. Woods** 1995. "Urethane foams and air leakage control" *Home Energy* Vol. 12 (4), published Jul-Aug 1995.
- Brown, Evan** 1999. *Energy Performance Evaluation of New Homes in Arkansas*, Evan Brown, consultant to the Arkansas Energy Office, December 1999, www.energycodes.gov/implement/pdfs/Arkansas_rpt.pdf
- Building Science Corporation** 2006. *Read This Before You Design, Build, or Renovate* www.buildingscience.com/documents/primers/plonearticlemultipage.2006-12-05.5229931729/section-2-recommendations
- Building Science Corporation** 2009a. "Air Barriers—Tub, Shower and Fireplace Enclosures," Information Sheet 407 for All Climates 5/20/2009, prepared by BSC for DOE's Building America program, www.buildingscience.com/documents/information-sheets/4-air-barriers/air-barriers2014tub-shower-and-fireplace-enclosures/?searchterm=building%20america
- Building Science Corporation** 2009b. "Air Sealing Windows," Information Sheet 406 for All Climates 5/20/2009, prepared by BSC for DOE's Building America program, www.buildingscience.com/documents/information-sheets/4-air-barriers/sealing-air-barrier-penetrations/?searchterm=building%20america
- Building Science Corporation** 2009c. "Critical Seal (Spray Foam at Rim Joist)" Information Sheet 408 for All Climates 09/18/2009, prepared by BSC for DOE's Building America program, www.buildingscience.com/documents/information-sheets/4-air-barriers/info-408-critical-seal-spray-foam-at-rim-joist/?searchterm=building%20america
- Building Science Corporation** 2009d. *Duct Sealing*, Information Sheet 603, prepared by BSC for DOE's Building America program. www.buildingscience.com/documents/information-sheets/hvac-plumbing-and-electrical/information-sheet-duct-sealing/?searchterm=building%20america
- Building Science Corporation** 2009e. "Sealing Air Barrier Penetrations," Information Sheet 405 for All Climates 5/20/2009, prepared by BSC for DOE's Building America program, www.buildingscience.com/documents/information-sheets/4-air-barriers/sealing-air-barrier-penetrations/?searchterm=building%20america
- Conbere, Susan and Kate Fried** 2006. "A Doctor in the House; Building performance testing has given one Illinois remodeler an edge in his market - and on the books," *Professional Remodeler*, June 1, 2006.
- Consumer Product Safety Commission** 2010. "What You Should Know About Combustion Appliances and Indoor Air Pollution." CPSC Document #452, accessed 3/12/2010, www.cpsc.gov/cpscpub/pubs/452.html
- Cummings, J.B., J.J. Tooley, N. Moyer, and R. Dunsmore**, "Impacts of duct leakage on infiltration rates, space conditioning energy use, and peak electrical demand in Florida homes," in *Proceedings of the 1990 ACEEE Summer Study on Energy Efficiency in Buildings*, Asilomar, CA, (1990), pp. 69-76.
- Dalieux P and C Nicolas** 1990. "Ventilation Perturbations Due to an Open Fireplace in a House." *Energy and Buildings* 14(3):211-214
- Davis** 2001. *Whole House Fan Installation*, Building Department, City of Davis, California, July 23, 2001. www.city.davis.ca.us/cdd/pdfs/Whole_House_Fan.pdf
- Granade, HC, J Creyts, A Derkach, P Farese, S Nyquist, and K Ostrowski** 2009. *Unlocking Energy Efficiency in the US Economy*. McKinsey and Company. www.mckinsey.com/client-service/electricpower/naturalgas/US_energy_efficiency/
- House Energy** 2009. "Ventilation and Electrical Penetrations," webpage, www.house-energy.com/AirLeaking/HvacAL.html
- Iowa Energy Center** 2008. *Home Tightening, Insulation, and Ventilation*, Home Series 1, Iowa Energy Center, Ames, Iowa. www.energy.iastate.edu/homeseries/downloads/HomeSeries1.pdf
- 2009 International Residential Code For One- and Two-Family Dwellings.** www.iccsafe.org
- Jump, D. and M. Modera** 1994. *Energy Impacts of Attic Duct Retrofits in Sacramento Houses*, LBL-35375, prepared by Lawrence Berkeley National Laboratory, for the U.S. Department of Energy, Washington, DC.
- Karins, N.H., A. Tuluca, and M. Modera** 1997. *Effectiveness of Duct Sealing and Duct Insulation in Multi-Family Buildings*. Prepared by Steven Winter Associates and Lawrence Berkeley National Laboratory for the New York State Energy Research and Development Authority and the U.S. Department of Energy.
- Lstiburek, Joseph** 2004a. *Builders Guides*. Guides to mixed humid, hot-dry, mixed-dry, and cold climates, for purchase at www.eeba.org/bookstore.
- Lstiburek, Joseph W.** 2004b. *Conditioned Crawl Space Construction, Performance and Codes*, Research Report - 0401, Building Science Corporation, www.buildingscience.com

- Lstiburek, Joseph** 2006. *EEBA Water Management Guide*, available for purchase at www.eeba.org/bookstore/prod-Water_Management_Guide-9.aspx
- Lstiburek, Joseph** 2008. *Concrete Floor Problems*, BSI-003, Building Science.com. www.buildingscience.com/documents/insights/bsi-003-concrete-floor-problems
- Lstiburek, Joseph** 2010. *Guide to Attic Air Sealing*. Prepared for U.S. Department of Energy by Building Science Corporation. www.buildingscience.com/documents/primers/guide-to-attic-air-sealing-with-details/?searchterm=air%20sealing
- Lugano, Fred** 1998. "First Step in Cellulose Sealing: Spot the Style," *Home Energy Magazine Online* May/June 1998, www.homeenergy.org/archive/hem.dis.anl.gov/eehem/98/980508.html
- McCullough, Jeff J. and Kelly L. Gordon** 2002. "High Hats, Swiss Cheese, and Fluorescent Lighting?" *Proceedings of the 2002 ACEEE Summer Study*, prepared by PNNL. www.aceee.org/conf/bldindex.htm
- Moriarta, Courtney** 2008. "Fixing Air Leakage in Connecticut Town Houses," *Home Energy Magazine* July/Aug 2008, p 28-30, www.swinter.com/news/documents/FixingAirLeakage.pdf&
- ORNL**. "Sealing Duct Leaks Saves Energy and Money," Oak Ridge National Laboratory, www.ornl.gov/info/ornlreview/rev28_2/text/duct.htm.
- Sherman, M. H., I. S. Walker, and D.J. Dicerkhoff** 2000. "Stopping Duct Quacks: Longevity of Residential Duct Sealants," in *Proceedings of the 2000 ACEEE Summer Study on Energy Efficiency in Buildings*, prepared by Lawrence Berkeley National Laboratory. www.osti.gov/bridge/product.biblio.jsp?query_id=1&page=3&osti_id=776574
- Southface Energy Institute** 1999. "Whole House Fan: Installing and using a whole house fan" Energy Technical Bulletin 10, Southface Energy Institute, Atlanta Georgia, www.southface.org/web/resources&services/publications/factsheets/housefan.pdf
- Stovall, T. K., T. Petrie, J. Kosny, P.W. Childs, J.A. Atchley, and K. D. Hulvey** 2007. "An Exploration of Wall Retrofit Best Practices," *Proceedings of the Thermal Performance of the Exterior Envelopes of Whole Buildings X Conference*, Clearwater Beach, FL, USA, Dec 02-07, 2007.
- Tyrol, Mark D and Joe Pate** 2007. Seal Fireplace Dampers with Weather Stripping to Conserve Energy, in *Proceedings of the 3rd International Conference on Environmental Science and Technology 2007*, August 5-9, 2007, Houston, Texas, prepared by Tyrol Engineering, LLC. http://hearth.com/econtent/index.php/wiki/Seal_Fireplace_Damper/
- U.S. Department of Energy** 1999. *Whole House Fan: How to Install and Use a Whole House Fan*, DOE/GO-10099-745, prepared by Southface Energy Institute and Oak Ridge National Laboratory for the U.S. Department of Energy. http://apps1.eere.energy.gov/buildings/publications/pdfs/building_america/26291.pdf
- U.S. Department of Energy** 2000a. *Air Sealing Fact Sheet*, Prepared by Southface Energy Institute and Oak Ridge National Laboratory. http://apps1.eere.energy.gov/buildings/publications/pdfs/building_america/26446.pdf
- U.S. Department of Energy** 2000b. *Attic Access Technology Fact Sheet*. Prepared by Southface Energy Institute and Oak Ridge National Laboratory. www.ornl.gov/sci/roofs+walls/insulation/fact%20sheets/attic%20access.pdf
- U.S. Department of Energy** 2009a. *Attic Access Insulation and Air Sealing*. www.energysavers.gov/your_home/insulation_airsealing/index.cfm/mytopic=11400
- U.S. Department of Energy** 2009b. "Energy Savers: Sealing Air Leaks," www1.eere.energy.gov/consumer/tips/air_leaks.html
- U.S. Department of Energy** 2009c. "Energy Savers: Your Home - Weather Stripping." DOE www.energysavers.gov/your_home/insulation_airsealing/index.cfm/mytopic=11280
- U.S. Environmental Protection Agency** 2008a. *A Do-It-Yourself Guide to Sealing and Insulating with ENERGY STAR*. EPA, May 2008, www.energystar.gov/index.cfm?c=diy.diy_index
- U.S. Environmental Protection Agency** 2008b. *ENERGY STAR Qualified Homes Thermal Bypass Checklist Guide*. www.energystar.gov/ia/partners/bldrs_lenders_raters/downloads/TBC_Guide_062507.pdf
- U.S. Environmental Protection Agency** 2008c. "Indoor Air Quality and Attics." www.epa.gov/iaq/homes/hip-attic.html
- U.S. Environmental Protection Agency** 2009a. *Duct Sealing*. EPA, Feb 2009, www.energystar.gov/ia/products/heat_cool/ducts/DuctSealingBrochure04.pdf
- U.S. Environmental Protection Agency** 2009b. *Model Standards and Techniques for Control of Radon in New Residential Buildings*. Cited 6/18/09. www.epa.gov/radon/pubs/newconst.html#Principles
- U.S. Environmental Protection Agency** 2009c. *Sealing Air Leaks: Basement* www.energystar.gov/index.cfm?c=diy.diy_sealing_basement
- U.S. Environmental Protection Agency** 2010. "Indoor airPLUS Building Professionals." www.epa.gov/indoorairplus/building_professionals.html
- U.S. Environmental Protection Agency and U.S. Department of Energy** 2010. *What to Expect from Home Performance with ENERGY STAR*, accessed 3/12/2010. www.energystar.gov/homeperformance
- University of Illinois Extension Office** "Five Steps to a Healthier Garage." <http://web.extension.uiuc.edu/will/factsheets/family116.html>

Visit our Web sites at:



www.buildingamerica.gov



www.pathnet.org



www.energystar.gov

Research and Development of Buildings

Our nation's buildings consume more energy than any other sector of the U.S. economy, including transportation and industry. Fortunately, the opportunities to reduce building energy use—and the associated environmental impacts—are significant.

DOE's Building Technologies Program works to improve the energy efficiency of our nation's buildings through innovative new technologies and better building practices. The program focuses on two key areas:

- Emerging Technologies
Research and development of the next generation of energy-efficient components, materials, and equipment
- Technology Integration of new technologies with innovative building methods to optimize building performance and savings

Building America Program

George S. James • New Construction • 202-586-9472 • fax: 202-586-8134 • e-mail: George.James@ee.doe.gov

Lew Pratsch • Existing Homes • 202-586-1512 • fax: 202-586-8185 • e-mail: Lew.Pratsch@ee.doe.gov

Building America Program • Office of Building Technologies, EE-2J • U.S. Department of Energy • 1000 Independence Avenue, S.W. • Washington, D.C. 20585-0121 • www.buildingamerica.gov

Building Industry Research Alliance (BIRA)

Robert Hammon • ConSol • 7407 Tam O'Shanter Drive #200 • Stockton, CA 95210-3370 • 209-473-5000 • fax: 209-474-0817 • e-mail: Rob@consol.ws • www.bira.ws

Building Science Consortium (BSC)

Betsy Pettit • Building Science Consortium (BSC) • 70 Main Street • Westford, MA 01886 • 978-589-5100 • fax: 978-589-5103 • e-mail: Betsy@buildingscience.com • www.buildingscience.com

Consortium for Advanced Residential Buildings (CARB)

Steven Winter • Steven Winter Associates, Inc. • 50 Washington Street • Norwalk, CT 06854 • 203-857-0200 • fax: 203-852-0741 • e-mail: swinter@swinter.com • www.carb-swa.com

Davis Energy Group

David Springer • Davis Energy Group • 123 C Street • Davis, CA 95616 • 530-753-1100 • fax: 530-753-4125 • e-mail: springer@davisenergy.com • deg@davisenergy.com • www.davisenergy.com/index.html

IBACOS Consortium

Brad Oberg • IBACOS Consortium • 2214 Liberty Avenue • Pittsburgh, PA 15222 • 412-765-3664 • fax: 412-765-3738 • e-mail: boberg@ibacos.com • www.ibacos.com

Industrialized Housing Partnership (IHP)

Philip Fairey • Florida Solar Energy Center • 1679 Clearlake Road • Cocoa, FL 32922 • 321-638-1005 • fax: 321-638-1439 • e-mail: pfairey@fsec.ucf.edu • www.baihp.org

National Association of Home Builders (NAHB) Research Center

Tom Kenney • National Association of Home Builders (NAHB) Research Center • 400 Prince George's Boulevard • Upper Marlboro, MD 20774 • 301-430-6246 • fax: 301-430-6180 • toll-free: 800-638-8556 • www.nahbrc.org

National Renewable Energy Laboratory

Ren Anderson • 1617 Cole Boulevard, MS-2722 • Golden, CO 80401 • 303-384-7433 • fax: 303-384-7540 • e-mail: ren_anderson@nrel.gov • www.nrel.gov

Tim Merrigan • 1617 Cole Boulevard, MS-2722 • Golden, CO 80401 • 303-384-7349 • fax: 303-384-7540 • e-mail: tim_merrigan@nrel.gov • www.nrel.gov

Oak Ridge National Laboratory

Pat M. Love • P.O. Box 2008 • One Bethel Valley Road • Oak Ridge, TN 37831 • 865-574-4346 • fax: 865-574-9331 • e-mail: lovepm@ornl.gov • www.ornl.gov

Pacific Northwest National Laboratory

Michael Baechler • 620 SW 5th, Suite 810 • Portland, OR 97204 • 503-417-7553 • fax: 503-417-2175 • e-mail: michael.baechler@pnl.gov • www.pnl.gov

Produced for the U.S. Department of Energy (DOE) by Pacific Northwest National Laboratory, Contract DE-AC05-76RLO 1830.

Printed with a renewable-source ink on paper containing at least 50% wastepaper, including 20% postconsumer waste.

U.S. DEPARTMENT OF
ENERGY

Energy Efficiency &
Renewable Energy

EERE Information Center

1-877-EERE-INF (1-877-337-3463)

www.eere.energy.gov/informationcenter

PNNL-19284 April 12, 2010

For information on **Building America** visit www.buildingamerica.gov. The website contains expanded case studies, technical reports, and best practices guides.